

Imperial College
London

School of Medicine

Year 1 – 2011/12

Molecules Cells and Disease

Lecture notes volume 1

Oct 13 - Nov 4, 2011

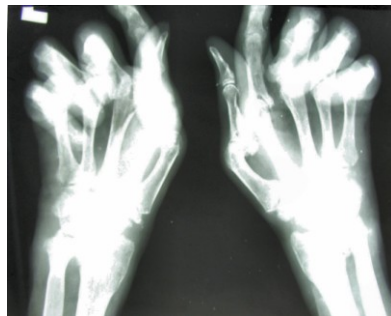
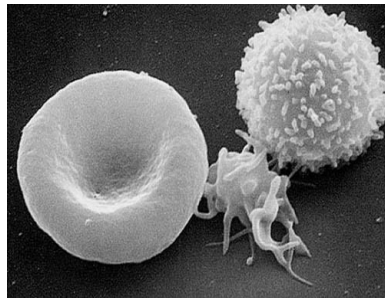

<http://commons.wikimedia.org/wiki>

Theme Leader: **Dr. Keith Gould**
tel: 020 7594 3724
email: k.gould@imperial.ac.uk

Deputy: **Dr. James Pease**
tel: 020 7594 3162
email: j.pease@imperial.ac.uk

<https://education.med.imperial.ac.uk>

MCD Year 1 Lecture notes – volume 1

This volume contains notes for lectures given from 13th October to 4th November 2011. They are provided in the order of presentation and are so printed that you can disassemble this book and reassemble notes in Course order to assist with revision, if you wish.

	<u>Page</u>
SOLE feedback	
Cells 1: Cells and organelles	Mike Ferenczi 1
Cells 2: Infectious agents	Brian Robertson 7
Cells 3: Cell membranes	Mike Ferenczi 9
Metabolism 1: Introduction to protein structure	James Pease 15
Nucleic acids 1: Nucleic acids and chromosomes	Birgit Leitinger 17
Cells 4: Blood and blood cells	Mike Emerson 21
Metabolism 2: Energetics and enzymes	James Pease 25
Nucleic acids 2: DNA replication, the cell cycle and mitosis	Birgit Leitinger 27
Metabolism 3: Metabolic pathways and ATP production I	James Pease 31
Nucleic acids 3: Gene organisation and transcription I	Laki Buluwela 33
Metabolism 4: Metabolic pathways and ATP production II	James Pease 35
Metabolism 5: Mitochondria and oxidative phosphorylation	James Pease 39
Nucleic acids 4: Gene organisation and transcription II	Laki Buluwela 43
Metabolism 6: Lipid metabolism	James Pease 47
Metabolism 7: Cholesterol	James Pease 51
Genetics 1: Mrs Jones' first consultation	Andrew Walley 55
Nucleic acids 5: Protein translation & post-translation modification	Tony Magee 57
Genetics 2: Mrs Jones (2) – risk of transmission of genetic disease	Jess Buxton 59
Genetics 3: More stories from the genetics clinic	Andrew Walley 63
Tissues 1: Epithelial cells	Peter Clark 65
Metabolism 8: Membrane trafficking	Tony Magee 69
Genetics 4: Cancer in families and in individuals	Alistair Reid 77
Nucleic acids 6: Analysis of nucleic acids	Tony Magee 79
Genetics 5: Prenatal diagnosis of genetic diseases	Ruwan Wimalasundera 81
Immunology 1: Introduction to immunology	Charles Bangham 91
Metabolism 9: Integration of metabolism	Gaby Da Silva 93
Tissues 2: Epithelial tissues	Peter Clark 97

SOLE FEEDBACK – Molecules, Cells and Disease

The following pages provide you with templates on which you can record your thoughts as the course proceeds. At the end of the course you can enter your views onto SOLE.

Please answer all questions by selecting the response which best reflects your view.

	Strongly Agree	Agree	Neutral	Disagree	Strongly Disagree
The content of this module is useful.	<input type="checkbox"/>	<input type="checkbox"/>	<input type="checkbox"/>	<input type="checkbox"/>	<input type="checkbox"/>
The support materials available for this module (e.g. handouts, web pages, problem sheets) are helpful.	<input type="checkbox"/>	<input type="checkbox"/>	<input type="checkbox"/>	<input type="checkbox"/>	<input type="checkbox"/>
I receive sufficient feedback and guidance.	<input type="checkbox"/>	<input type="checkbox"/>	<input type="checkbox"/>	<input type="checkbox"/>	<input type="checkbox"/>
Overall, I am satisfied with this module.	<input type="checkbox"/>	<input type="checkbox"/>	<input type="checkbox"/>	<input type="checkbox"/>	<input type="checkbox"/>

Please use this box for constructive feedback and suggestions for improvement.

SOLE FEEDBACK - INDIVIDUAL LECTURERS

Please note that for SOLE, a Lecturer's name will only appear once. This template gives you the opportunity to record your comments about each lecture in the order of delivery.

On the following section, you have an opportunity to record any comments and constructive feedback you have for each lecturer.

Lecturer and Lecture Title	The lecture(s) are well structured					The lecturer explains concepts clearly					The lecturer engages well with the students				
	Strongly Agree	Agree	Neutral	Disagree	Strongly Disagree	Strongly Agree	Agree	Neutral	Disagree	Strongly Disagree	Strongly Agree	Agree	Neutral	Disagree	Strongly Disagree
Mike Ferenczi Cells 1; Cells & organelles	<input type="checkbox"/>	<input type="checkbox"/>	<input type="checkbox"/>	<input type="checkbox"/>	<input type="checkbox"/>	<input type="checkbox"/>	<input type="checkbox"/>	<input type="checkbox"/>	<input type="checkbox"/>	<input type="checkbox"/>	<input type="checkbox"/>	<input type="checkbox"/>	<input type="checkbox"/>	<input type="checkbox"/>	<input type="checkbox"/>
Brian Robertson Cells 2; Infectious agents	<input type="checkbox"/>	<input type="checkbox"/>	<input type="checkbox"/>	<input type="checkbox"/>	<input type="checkbox"/>	<input type="checkbox"/>	<input type="checkbox"/>	<input type="checkbox"/>	<input type="checkbox"/>	<input type="checkbox"/>	<input type="checkbox"/>	<input type="checkbox"/>	<input type="checkbox"/>	<input type="checkbox"/>	<input type="checkbox"/>
Mike Ferenczi Cells 3: Cell membranes	<input type="checkbox"/>	<input type="checkbox"/>	<input type="checkbox"/>	<input type="checkbox"/>	<input type="checkbox"/>	<input type="checkbox"/>	<input type="checkbox"/>	<input type="checkbox"/>	<input type="checkbox"/>	<input type="checkbox"/>	<input type="checkbox"/>	<input type="checkbox"/>	<input type="checkbox"/>	<input type="checkbox"/>	<input type="checkbox"/>
James Pease Metabolism 1: Introduction to protein structure	<input type="checkbox"/>	<input type="checkbox"/>	<input type="checkbox"/>	<input type="checkbox"/>	<input type="checkbox"/>	<input type="checkbox"/>	<input type="checkbox"/>	<input type="checkbox"/>	<input type="checkbox"/>	<input type="checkbox"/>	<input type="checkbox"/>	<input type="checkbox"/>	<input type="checkbox"/>	<input type="checkbox"/>	<input type="checkbox"/>
Birgit Leitinger Nucleic acids 1: Nucleic acids and chromosomes	<input type="checkbox"/>	<input type="checkbox"/>	<input type="checkbox"/>	<input type="checkbox"/>	<input type="checkbox"/>	<input type="checkbox"/>	<input type="checkbox"/>	<input type="checkbox"/>	<input type="checkbox"/>	<input type="checkbox"/>	<input type="checkbox"/>	<input type="checkbox"/>	<input type="checkbox"/>	<input type="checkbox"/>	<input type="checkbox"/>
Mike Emerson Cells 4 : Blood & blood cells	<input type="checkbox"/>	<input type="checkbox"/>	<input type="checkbox"/>	<input type="checkbox"/>	<input type="checkbox"/>	<input type="checkbox"/>	<input type="checkbox"/>	<input type="checkbox"/>	<input type="checkbox"/>	<input type="checkbox"/>	<input type="checkbox"/>	<input type="checkbox"/>	<input type="checkbox"/>	<input type="checkbox"/>	<input type="checkbox"/>
James Pease Metabolism 2 : Energetics and enzymes	<input type="checkbox"/>	<input type="checkbox"/>	<input type="checkbox"/>	<input type="checkbox"/>	<input type="checkbox"/>	<input type="checkbox"/>	<input type="checkbox"/>	<input type="checkbox"/>	<input type="checkbox"/>	<input type="checkbox"/>	<input type="checkbox"/>	<input type="checkbox"/>	<input type="checkbox"/>	<input type="checkbox"/>	<input type="checkbox"/>
Birgit Leitinger Nuc. acids 2: DNA replication, the cell cycle and mitosis	<input type="checkbox"/>	<input type="checkbox"/>	<input type="checkbox"/>	<input type="checkbox"/>	<input type="checkbox"/>	<input type="checkbox"/>	<input type="checkbox"/>	<input type="checkbox"/>	<input type="checkbox"/>	<input type="checkbox"/>	<input type="checkbox"/>	<input type="checkbox"/>	<input type="checkbox"/>	<input type="checkbox"/>	<input type="checkbox"/>

Lecturer and Lecture Title	The lecture(s) are well structured					The lecturer explains concepts clearly					The lecturer engages well with the students				
	Strongly Agree	Agree	Neutral	Disagree	Strongly Disagree	Strongly Agree	Agree	Neutral	Disagree	Strongly Disagree	Strongly Agree	Agree	Neutral	Disagree	Strongly Disagree
James Pease : Metabolism 3: Metabolic pathways & ATP production I	<input type="checkbox"/>	<input type="checkbox"/>	<input type="checkbox"/>	<input type="checkbox"/>	<input type="checkbox"/>	<input type="checkbox"/>	<input type="checkbox"/>	<input type="checkbox"/>	<input type="checkbox"/>	<input type="checkbox"/>	<input type="checkbox"/>	<input type="checkbox"/>	<input type="checkbox"/>	<input type="checkbox"/>	<input type="checkbox"/>
Laki Buluwela Nucleic acids 3 : Gene organization & transcription I	<input type="checkbox"/>	<input type="checkbox"/>	<input type="checkbox"/>	<input type="checkbox"/>	<input type="checkbox"/>	<input type="checkbox"/>	<input type="checkbox"/>	<input type="checkbox"/>	<input type="checkbox"/>	<input type="checkbox"/>	<input type="checkbox"/>	<input type="checkbox"/>	<input type="checkbox"/>	<input type="checkbox"/>	<input type="checkbox"/>
James Pease Metabolism 4: Metabolic pathways & ATP production II	<input type="checkbox"/>	<input type="checkbox"/>	<input type="checkbox"/>	<input type="checkbox"/>	<input type="checkbox"/>	<input type="checkbox"/>	<input type="checkbox"/>	<input type="checkbox"/>	<input type="checkbox"/>	<input type="checkbox"/>	<input type="checkbox"/>	<input type="checkbox"/>	<input type="checkbox"/>	<input type="checkbox"/>	<input type="checkbox"/>
James Pease Metabolism 5 : Mitochondria and oxidative phosphorylation	<input type="checkbox"/>	<input type="checkbox"/>	<input type="checkbox"/>	<input type="checkbox"/>	<input type="checkbox"/>	<input type="checkbox"/>	<input type="checkbox"/>	<input type="checkbox"/>	<input type="checkbox"/>	<input type="checkbox"/>	<input type="checkbox"/>	<input type="checkbox"/>	<input type="checkbox"/>	<input type="checkbox"/>	<input type="checkbox"/>
Laki Buluwela Nucleic acids 4 : Gene organization & transcription II	<input type="checkbox"/>	<input type="checkbox"/>	<input type="checkbox"/>	<input type="checkbox"/>	<input type="checkbox"/>	<input type="checkbox"/>	<input type="checkbox"/>	<input type="checkbox"/>	<input type="checkbox"/>	<input type="checkbox"/>	<input type="checkbox"/>	<input type="checkbox"/>	<input type="checkbox"/>	<input type="checkbox"/>	<input type="checkbox"/>
James Pease Metabolism 6 : Lipid metabolism	<input type="checkbox"/>	<input type="checkbox"/>	<input type="checkbox"/>	<input type="checkbox"/>	<input type="checkbox"/>	<input type="checkbox"/>	<input type="checkbox"/>	<input type="checkbox"/>	<input type="checkbox"/>	<input type="checkbox"/>	<input type="checkbox"/>	<input type="checkbox"/>	<input type="checkbox"/>	<input type="checkbox"/>	<input type="checkbox"/>
James Pease Metabolism 7 : Cholesterol	<input type="checkbox"/>	<input type="checkbox"/>	<input type="checkbox"/>	<input type="checkbox"/>	<input type="checkbox"/>	<input type="checkbox"/>	<input type="checkbox"/>	<input type="checkbox"/>	<input type="checkbox"/>	<input type="checkbox"/>	<input type="checkbox"/>	<input type="checkbox"/>	<input type="checkbox"/>	<input type="checkbox"/>	<input type="checkbox"/>
Andrew Walley Genetics 1 : Mrs Jones' first consultation	<input type="checkbox"/>	<input type="checkbox"/>	<input type="checkbox"/>	<input type="checkbox"/>	<input type="checkbox"/>	<input type="checkbox"/>	<input type="checkbox"/>	<input type="checkbox"/>	<input type="checkbox"/>	<input type="checkbox"/>	<input type="checkbox"/>	<input type="checkbox"/>	<input type="checkbox"/>	<input type="checkbox"/>	<input type="checkbox"/>
Tony Magee Nucleic acids 5 : Protein translation and post-translation modification	<input type="checkbox"/>	<input type="checkbox"/>	<input type="checkbox"/>	<input type="checkbox"/>	<input type="checkbox"/>	<input type="checkbox"/>	<input type="checkbox"/>	<input type="checkbox"/>	<input type="checkbox"/>	<input type="checkbox"/>	<input type="checkbox"/>	<input type="checkbox"/>	<input type="checkbox"/>	<input type="checkbox"/>	<input type="checkbox"/>

Lecturer and Lecture Title	The lecture(s) are well structured					The lecturer explains concepts clearly					The lecturer engages well with the students				
	Strongly Agree	Agree	Neutral	Disagree	Strongly Disagree	Strongly Agree	Agree	Neutral	Disagree	Strongly Disagree	Strongly Agree	Agree	Neutral	Disagree	Strongly Disagree
Jess Buxton Genetics 2 : Mrs Jones (2)-risk of transmission of genetic disease	<input type="checkbox"/>	<input type="checkbox"/>	<input type="checkbox"/>	<input type="checkbox"/>	<input type="checkbox"/>	<input type="checkbox"/>	<input type="checkbox"/>	<input type="checkbox"/>	<input type="checkbox"/>	<input type="checkbox"/>	<input type="checkbox"/>	<input type="checkbox"/>	<input type="checkbox"/>	<input type="checkbox"/>	<input type="checkbox"/>
Andrew Walley Genetics 3 : More stories from the genetics clinic	<input type="checkbox"/>	<input type="checkbox"/>	<input type="checkbox"/>	<input type="checkbox"/>	<input type="checkbox"/>	<input type="checkbox"/>	<input type="checkbox"/>	<input type="checkbox"/>	<input type="checkbox"/>	<input type="checkbox"/>	<input type="checkbox"/>	<input type="checkbox"/>	<input type="checkbox"/>	<input type="checkbox"/>	<input type="checkbox"/>
Peter Clark Tissues 1 : Epithelial cells	<input type="checkbox"/>	<input type="checkbox"/>	<input type="checkbox"/>	<input type="checkbox"/>	<input type="checkbox"/>	<input type="checkbox"/>	<input type="checkbox"/>	<input type="checkbox"/>	<input type="checkbox"/>	<input type="checkbox"/>	<input type="checkbox"/>	<input type="checkbox"/>	<input type="checkbox"/>	<input type="checkbox"/>	<input type="checkbox"/>
Tony Magee Metabolism 8 : Membrane trafficking	<input type="checkbox"/>	<input type="checkbox"/>	<input type="checkbox"/>	<input type="checkbox"/>	<input type="checkbox"/>	<input type="checkbox"/>	<input type="checkbox"/>	<input type="checkbox"/>	<input type="checkbox"/>	<input type="checkbox"/>	<input type="checkbox"/>	<input type="checkbox"/>	<input type="checkbox"/>	<input type="checkbox"/>	<input type="checkbox"/>
Alistair Reid Genetics 4 : Cancer in families and individuals	<input type="checkbox"/>	<input type="checkbox"/>	<input type="checkbox"/>	<input type="checkbox"/>	<input type="checkbox"/>	<input type="checkbox"/>	<input type="checkbox"/>	<input type="checkbox"/>	<input type="checkbox"/>	<input type="checkbox"/>	<input type="checkbox"/>	<input type="checkbox"/>	<input type="checkbox"/>	<input type="checkbox"/>	<input type="checkbox"/>
Tony Magee Nucleic acids 6 : Analysis of nucleic acids	<input type="checkbox"/>	<input type="checkbox"/>	<input type="checkbox"/>	<input type="checkbox"/>	<input type="checkbox"/>	<input type="checkbox"/>	<input type="checkbox"/>	<input type="checkbox"/>	<input type="checkbox"/>	<input type="checkbox"/>	<input type="checkbox"/>	<input type="checkbox"/>	<input type="checkbox"/>	<input type="checkbox"/>	<input type="checkbox"/>
Ruwan Wimalasundera Genetics 5 : Prenatal diagnosis of genetic diseases	<input type="checkbox"/>	<input type="checkbox"/>	<input type="checkbox"/>	<input type="checkbox"/>	<input type="checkbox"/>	<input type="checkbox"/>	<input type="checkbox"/>	<input type="checkbox"/>	<input type="checkbox"/>	<input type="checkbox"/>	<input type="checkbox"/>	<input type="checkbox"/>	<input type="checkbox"/>	<input type="checkbox"/>	<input type="checkbox"/>
Charles Bangham Immunology 1 : Introduction to immunology	<input type="checkbox"/>	<input type="checkbox"/>	<input type="checkbox"/>	<input type="checkbox"/>	<input type="checkbox"/>	<input type="checkbox"/>	<input type="checkbox"/>	<input type="checkbox"/>	<input type="checkbox"/>	<input type="checkbox"/>	<input type="checkbox"/>	<input type="checkbox"/>	<input type="checkbox"/>	<input type="checkbox"/>	<input type="checkbox"/>

	The lecture(s) are well structured					The lecturer explains concepts clearly					The lecturer engages well with the students				
Lecturer and Lecture Title	Strongly Agree	Agree	Neutral	Disagree	Strongly Disagree	Strongly Agree	Agree	Neutral	Disagree	Strongly Disagree	Strongly Agree	Agree	Neutral	Disagree	Strongly Disagree
Gaby Da Silva Metabolism 9: Integration of metabolism	<input type="checkbox"/>	<input type="checkbox"/>	<input type="checkbox"/>	<input type="checkbox"/>	<input type="checkbox"/>	<input type="checkbox"/>	<input type="checkbox"/>	<input type="checkbox"/>	<input type="checkbox"/>	<input type="checkbox"/>	<input type="checkbox"/>	<input type="checkbox"/>	<input type="checkbox"/>	<input type="checkbox"/>	<input type="checkbox"/>
Peter Clark Tissues 2: Epithelial tissues	<input type="checkbox"/>	<input type="checkbox"/>	<input type="checkbox"/>	<input type="checkbox"/>	<input type="checkbox"/>	<input type="checkbox"/>	<input type="checkbox"/>	<input type="checkbox"/>	<input type="checkbox"/>	<input type="checkbox"/>	<input type="checkbox"/>	<input type="checkbox"/>	<input type="checkbox"/>	<input type="checkbox"/>	<input type="checkbox"/>

CELLS 1

Cells and Organelles

Professor Michael Ferenczi (m.ferenczi@imperial.ac.uk)

Learning objectives

- Understand what constitutes a cell, and the scale of cells and molecules
- Demonstrate the following on a suitable transmission electron micrograph: nucleus; nucleolus; nuclear envelope; mitochondrion; rough endoplasmic reticulum; smooth endoplasmic reticulum; ribosomes; Golgi apparatus; secretory granule; plasma membrane; cytoskeletal components.
- Identify the essential characteristics of prokaryotic and eukaryotic cells.
- Explain the relationship of individual cells to the organisation of the whole body.
- Understand that cancer is a disorder of cell division

Cell biology ?

The body is made up of organs and tissues

All organs and tissues are made up of 'cells' and of 'stuff in-between'

Cells are separated from the 'stuff in-between' by membranes

Some cells can live independently: protozoa

When cells come together, they can 'specialise' to give the organism an advantage

Some protozoa form occasional colonies when individual cells specialise (e.g. slime moulds, dictyostelium)

<http://www.ncbi.nlm.nih.gov/books/bv.fcgi?call=bv.View..ShowTOC&rid=cell.TOC&depth=2>

Cells assemble to form tissues

Some cells divide to form colonies or clones

These cells specialise: particular genes are switched on, triggered by signals from their immediate environment (developmental biology).

Polarity is established

Genes produce enzymes which induce the formation of specialised cytoskeleton (cell shape) organelles, cell-cell contacts, secretion and absorption

Scales

Dimension of Man/Woman

You are familiar with the size of people

Linear dimension (metres)

Volume (Litres)

Weight (Kg)

Dimension of a Cell

Size of a cell ? (micrometres, μm ?)

Volume of a cell ? (nanolitres, nL ?)

Weight of a cell : (density = 1.06), ng

Dimension of a virus (nanometres, nm ?)

Dimensions of a molecule (nm, Angstroms ?)

Concentration of molecules (molarity)

Dimension of an atom

Of a chemical bond

Number of molecules in one Mole

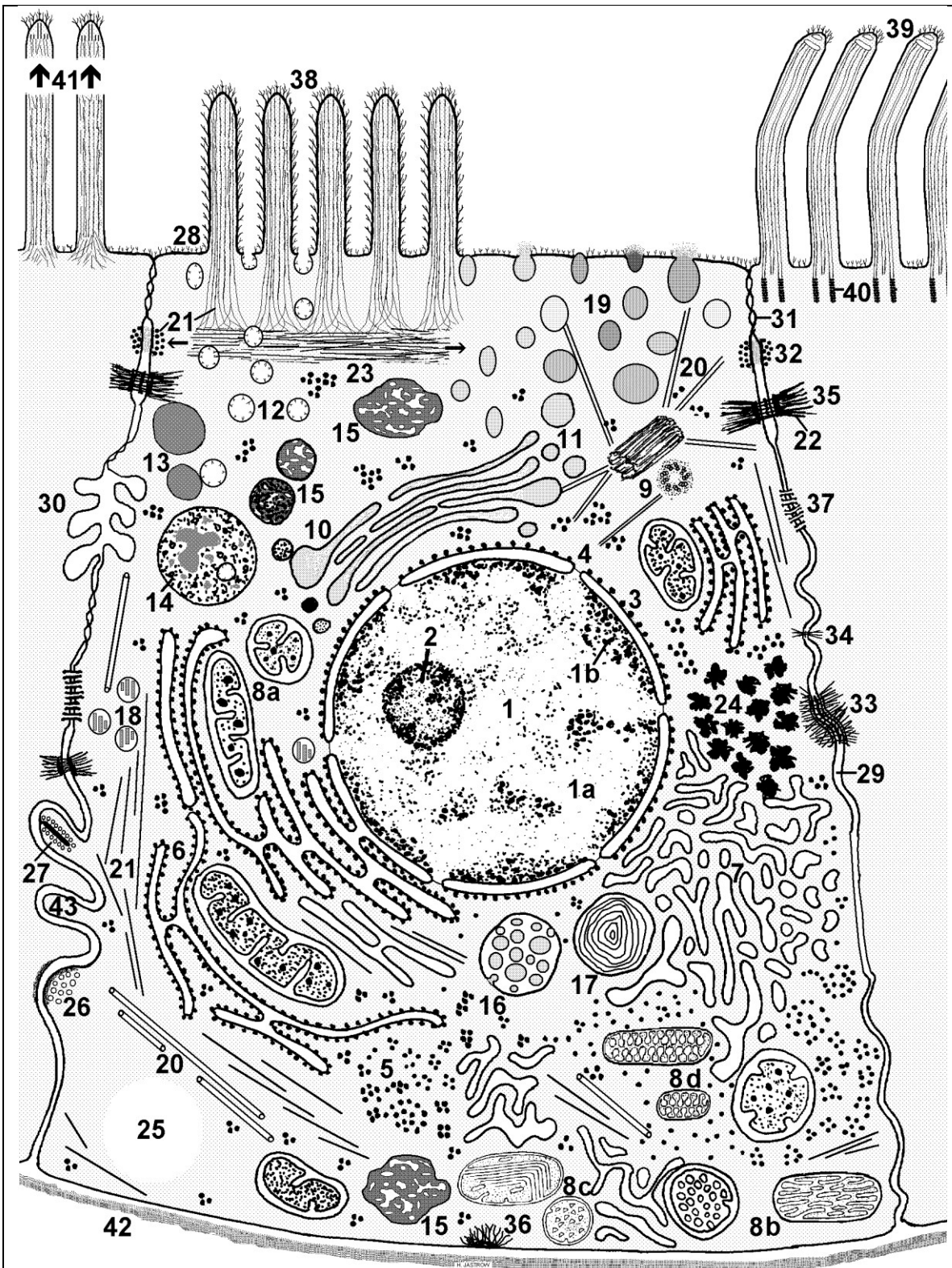

Diagram of a thin section of an idealised cell viewed in the electron microscope
<http://www.uni-mainz.de/FB/Medizin/Anatomie/workshop/EM/Schemazell.html>

Organelles

- | | |
|--|--|
| 1 Nucleus | 20 Microtubules |
| 1a Euchromatin | 21 Actin filaments |
| 1b Heterochromatin | 22 Intermediate filaments linking to desmosomes |
| 2 Nucleolus | 24 Glycogen granules |
| 3 Nuclear membrane | 25 Fat droplets |
| 4 Nucleopore | 26 Synapse |
| 5 Ribosomes | 27 Synaptic body |
| 6 Rough endoplasmic reticulum (with ribosomes) | 28 Cell membrane with glycocalyx (polysaccharides and glycoproteins) |
| 7 Smooth endoplasmic reticulum | 29 Intercellular space |
| 8a Longitudinal- and cross-sections of a mitochondrion showing cristae | 30 |
| 8b Longitudinal- and cross-sections of a mitochondrion showing tubules | 31 Tight junction |
| 8c Longitudinal- and cross-sections of a mitochondrion of the prismatic type | 32 Adherens junction |
| 8d Longitudinal- and cross-sections of a mitochondrion showing saccules | 33 Fascia Adherens with actin filaments (cardiac) |
| 9 Longitudinal- and cross-sections of a centriole | 34 Punctum Adherens |
| 10 Golgi Apparatus | 35 Macula Adherens (desmosome) |
| 11 Golgi vesicles | 36 Hemidesmosome (joins cell to basal lamina) |
| 12 Endopinosomes, endopinocytotic vesicles | 37 Gap junction |
| 13 primary lysosomes | 38 Microvilli with glycocalyx |
| 14 secondary lysosomes, phagocytosomes | 39 Cilia |
| 15 tertiary lysosomes | 40 Basal bodies of microcilia |
| 16, 17 Multivesicular bodies | 41 Stereocilia |
| 18 peroxisomes, microbodies | 42 Basal lamina (basement membrane or basement lamina) |
| 19 Secretory granules | |

Cytosol:

- | | |
|--|-------------|
| solutes include: | amino acids |
| soluble proteins | mRNA |
| ions (K^+ , Na^+ , Mg^{2+} , Ca^{2+} , PO_4^{2-} , Cl^-) | tRNA |
| sugars | Lipids |
| Nucleotides: e.g. ATP, cAMP, GTP | peptides |

In-between cells

- | | |
|--|--|
| Basement membrane: | vitamins |
| selective barrier for macromolecules | amino acids |
| type IV collagen network, laminins, type XV collagen | hormones |
| | nucleotides (ATP) |
| | lipids |
| | cholesterol |
| Extracellular fluid: | <i>Lymph</i> |
| ions (Na^+ , Cl^- , PO_4^{2-} , CO_3^{2-} , Mg^{2+} , Ca^{2+}) | <i>Plasma</i> |
| soluble proteins | <i>Saliva, urine, bile, sweat etc.</i> |
| soluble carbohydrates, sugars | |

Characteristics of all cells:

All cells have a cell membrane that separates the outside from the organised interior.

All cellular life contains DNA as its genetic material.

All cells contain several varieties of RNA molecules and proteins, most of the latter are enzymes. All cells are composed of the same basic chemicals: carbohydrates, proteins, nucleic acids, minerals, fats and vitamins.

All cells regulate the flow of nutrients and wastes that enter and leave the cell.

All cells reproduce and are the result of reproduction.

All cells require a supply of energy.

All cells are affected and respond to the reactions that are occurring within them and many of the environmental conditions around them; this information is continually processed to make metabolic decisions.

Eukaryotic cells evolved from aggregates of prokaryotic cells that became interdependent upon one another and eventually merged or fused into a single larger cell. Eukaryotic cells have a higher degree of organisation than prokaryotic cells, in that they contain many organelles or structures separated from the other cytoplasm components by a membrane

Cells are dynamic

Molecules move spontaneously

Diffusion, Brownian motion (temperature dependent)

Other forms of movement require energy

Hydrolysis of ATP

Transport of molecules against a concentration gradient

Movement of organelles

Tuning of hair cells in the ear

Movement of cell membranes, ruffling

Growth and migration of cells. Nerve growth, development

Cell division, movement of chromosomes

Muscle contraction, the heart beat

All require specialised motor proteins

Prokaryotes:

Prokaryotes include kingdoms of Monera (simple bacteria) and Archaea.

They are bags of molecules, held within a membrane and a cell wall and do not contain 'organelles'.

Prokaryotic cells may have photosynthetic pigments, such as is found in cyanobacteria ("blue bacteria").

Some prokaryotic cells have external whip-like flagella for locomotion or hair like pili for adhesion.

Prokaryotic cells come in multiple shapes: cocci (round), bacilli (rods), and spirilla or spirochetes (helical cells).

Bacteria

If you were bacteria,

- You have 0.001 times as much DNA as a eukaryotic cell.
- You live in a medium which has a viscosity about equal to asphalt.
- You have a wonderful "motor" for swimming. Unfortunately, your motor can only run in two directions and at one speed. Forward or reverse. In reverse your motor makes you turn flips or tumble. You can only do one or the other. You cannot stop.

- While you can "learn", you divide every twenty minutes and have to restart your education.
- **You can have sex, with males possessing a sexual apparatus for transferring genetic information to receptive females. However it is difficult to find each other. Furthermore, if you are female, nature gave you a severe problem. Every time you mate with a male, you turn into a male. In bacteria, "maleness" is an infective venereal disease.**
- However, at fairly high frequencies, spontaneous mutations cause you to turn into a female.
- Eukaryotes have enslaved some of your "brethren" to use as energy generating mitochondria and chloroplasts. They are also using you as a tool in a massive effort to understand genetics. The method of recombinant DNA is designed to exploit you for their own good.
- The last laugh may be yours. You have spent three and a half billion years practicing chemical warfare. Humans thought that antibiotics would end infectious diseases, but the overuse of drugs has resulted in the selection of drug resistant bacteria. They didn't realise that this was only the first battle, and now the war is ready to begin.
- **Humans think this is their era. A more truthful statement would be that we all live in the age of bacteria.**

Why cell biology?

Much of medical science is rooted in our deepening understanding of mechanisms at the cellular and molecular levels. Understanding modern medicine and modern research requires knowledge of cellular processes.

Development and repair is based on programming the cell cycle and turning on differentiation mechanisms.

Diseases are often problems of the cell:

- Cancer is when cellular development programs are failing.
- Infections occur when cellular defence mechanisms fail to prevent bacterial invasion
- Viruses take over the chemical machinery of cells

Questions about cells

What do we mean by a "cell"?

What are the structures inside a cell?

How are cell components made?

What is the energy driving cell processes?

What are the important features of a cell's shape?

How do cells link into layers?

How do they maintain a barrier?

How do they allow some things to cross the barrier?

What is their relationship to other nearby cells?

Cancer is a disorder of cell division

What causes cells to divide?

How do they know when to stop dividing?

What is the normal process of cell division?

What is the genetic material and how is it copied?

What happens if it is copied wrongly (= mutated)?

What might cause mutations?

Why don't all mutations cause cancer?

Cancer mutations

Mutations that can lead to cancer:

switch on of "divide" signals

switch off "don't divide" signals

loss of correction mechanism on DNA copying

loss of escape mechanism from cell division

loss of limit on number of times a cell can divide

loss of control keeping cell within tissue boundaries

ability to evade body defence mechanisms

ability to recruit blood vessels to growing tumour

ability to migrate into blood stream or lymph vessels

ability to establish tumours in the "wrong" tissue

Seeing and measuring

Cells and organelles are visible in the microscope

Molecules usually are not visible

Yet, all cell processes are chemical reactions involving molecules

Much research aims at making the invisible visible.

There are less direct ways to know about the behaviour of molecules

Spectroscopy

X-ray diffraction

Important issues are:

Time resolution: static or dynamic information

Alterations to the natural process - artefacts

CELLS 2

Infectious agents

Dr Brian Robertson

Reader in Systems Microbiology

Centre for Molecular Microbiology and Infection, SK campus

Learning objectives

- Name the main types of infectious agents causing disease in humans
- Give examples of each type of infectious agent and the disease it causes
- List the key differences between prokaryotes and eukaryotes
- Name the distinguishing features of the different types of infectious agent and explain how they replicate

The following features distinguish prokaryotic cells from eukaryotic cells

Cell walls of prokaryotes contain, and the membranes of are limited to the cell membrane. There are no distinct organelles in, while nuclei containing one or morechromosomes are found in DNA in prokaryotes is generally in the form of a single chromosome.

A variety of pathogens can cause human infectious disease, though these organisms represent a fraction of the commensal bacteria making up the normal human flora, which is beneficial to health.

The main types include:

1. are not free living organisms but obligate intracellular parasites. e.g. SARS, HIV, Influenza. Intracellular replication followed by budding.
2. are prokaryotes that replicate by e.g. *Neisseria meningitidis*, *Mycobacterium tuberculosis*, *Shigella* spp
3. are single celled eukaryotes that exist as or Systemic infections with these organisms (e.g. *Candida albicans*, *Aspergillus fumigatus*) often affect immuno-compromised people
4. are single-celled eukaryotes. e.g. (*Plasmodium* spp) malaria, *Leishmania* spp (leishmaniasis)
5. are multi-cellular organisms that include tapeworms, flukes and roundworms.

Size of the organisms and the size of their genomes differ.

Missing words

viruses, peptidoglycan, binary fission, helminths, yeasts, fungi, prokaryotes (x2), eukaryotes, protozoa, bacteria, filaments, linear, circular.

CELLS 3

Cell Membranes

Professor Michael Ferenczi (m.ferenczi@imperial.ac.uk)

Learning objectives

- Explain the formation of phospholipid bilayers in an aqueous environment.
- Draw the structure of phosphatidylcholine and identify the component parts.
- Describe the permeability properties of a phospholipid bilayer with respect to macromolecules, ions, water and organic compounds (including drugs).
- Distinguish simple diffusion, facilitated diffusion and active transport of ions and molecules across cell membranes.
- Categorise the functions of membrane proteins.
- Explain the movement of Na⁺ and K⁺ ions across the cell membrane against a concentration gradient and the consequences of failure of such a movement.
- Explain how the entry of glucose and amino acids into the cell against a concentration gradient is coupled to ATP dependent Na⁺ transport.
- Explain how external chemical signals can be sensed at the interior of a cell.

The cell is a bag

A cell is a bag containing chemicals:
genetic material (nucleic acids)
functional macromolecules (proteins)
energy stores (polysaccharides)
synthetic machinery
monomer subunits
machinery for making ATP, NADH, etc
metabolic intermediates
etc

What is the bag made of?

It is a biological membrane

It forms the limits of the cell (= plasma membrane or cell membrane)

It surrounds intracellular compartments (organelles)

Properties required

selective permeability

impermeable to macromolecules, biochemical intermediates

permeable to nutrients, waste products

transfer of information (= signal transduction)

Biological membranes are made of lipids

Lipids have a hydrophilic head (polar) and hydrophobic tail. To avoid water, the tails pack together. Suspended in water they form micelles or droplets. They can also arrange themselves into bilayers (a layer two molecules thick). Droplets in cells are called liposomes. Membranes surrounding cells and organelles are lipid bilayers.

Phospholipids are amphiphilic.

Some are saturated fatty acids, some are unsaturated.

Common constituents are phosphatidylethanolamine, phosphatidylserine, phosphatidylcholine and sphingomyelin. Lecithin is phosphatidylcholine.

Membranes also contain cholesterol which increases the membrane rigidity (decreases fluidity)

The lipid bilayer is asymmetric:

Glycolipids on the extracellular side of the membrane.

Negative charges inside the cell

How dynamic is a lipid bilayer?

Can lipids switch sides in the bilayer ?

This process, called "flip-flop," occurs less than once a month for any individual molecule.

Can lipids move (diffuse) within a monolayer ?

Lipid molecules readily exchange places with their neighbours *within* a monolayer ($\sim 10^7$ times a second). This gives rise to a rapid lateral diffusion, with a diffusion coefficient (D) of about 10^{-8} cm²/sec, which means that an average lipid molecule diffuses the length of a large bacterial cell (~ 2 μ m) in about 1 second.

Membranes are much more fluid than calculations for lipid bilayers would predict. Why ?

Membranes are dynamic

Membranes are:

Permeable to small neutral molecules

Impermeable to large, hydrophilic or charged molecules

Lipid bilayers are permeable to...

water molecules and a few other small, uncharged, molecules like oxygen (O₂) and carbon dioxide (CO₂) which diffuse freely in and out of the cell.

Diffusion of water across membrane is called osmosis

Diffusion down the concentration gradient is possible.

Diffusion against the concentration gradient requires energy or exchange and is called active transport. What is the energy source ?

Facilitated diffusion is movement of hydrophilic (charged) molecules down their concentration gradient through protein pores that hide the ionic charges from the hydrophobic core of the lipid bilayer. Proteins (or protein assemblies) offer a water-filled channel. The channel can be 'gated'.

Lipid bilayers are not permeable to:

- Cations (K⁺, Na⁺, Ca²⁺) but some do leak through, down the concentration gradient
- Anions (Cl⁻, HCO₃⁻)
- small hydrophilic molecules like glucose
- macromolecules like proteins and RNA

The fluid mosaic model

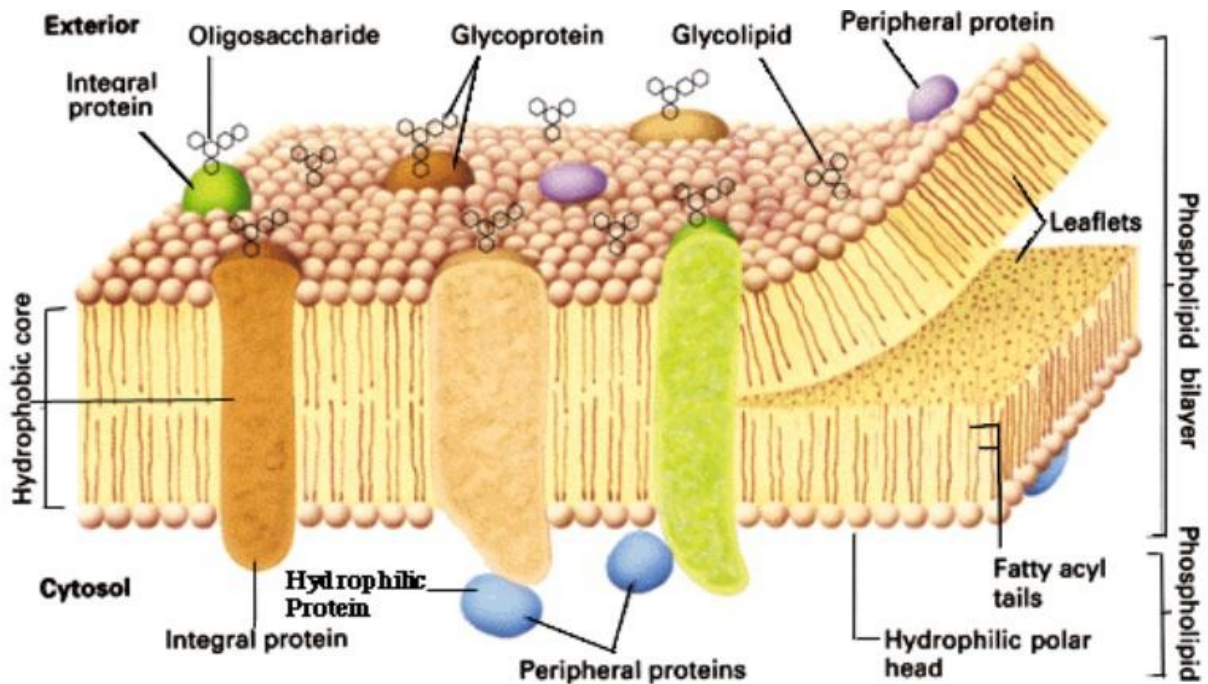

Membrane proteins

Cell membranes and organelle membranes contain proteins.

These proteins increase the cell fluidity.

They confer new properties to the membranes.

Many membrane proteins are involved in transport and in the transmission of signals. The proportion of protein to lipids vary from cell type to cell type. The protein composition is different in the inner and outer leaflets of the lipid bilayer. The protein composition also depends on the organelles.

Membrane	Lipid	Protein
Myelin sheath	80%	20%
Plasma membrane	50%	50%
Mitochondrial inner membrane	25%	75%

Functions of membrane proteins:

Transport (Na-Glucose transporter)

Receptor- for hormones and growth factors

Cell recognition and adhesion

Electron carrier (cellular respiration and photosynthesis in mitochondria and chloroplasts)

The sodium-potassium pump

The sodium-potassium pump is found in all cells and consists of two polypeptide chains, α and β , with 1000 and 300 amino acids respectively. The α -chain spans the membrane 10 times, forming a hydrophilic pore.

	Outside cell (ECF)	Inside cell (cytosol)
[Na ⁺]	High: 135 mM	Low: 18 mM
[K ⁺]	Low: 5 mM	High: 166 mM

The sodium-potassium pump

The transport of 2 K⁺ from the extracellular to the intracellular space in exchange for 3 Na⁺ is mediated by successive conformational transitions of the pump molecule. This is driven by phosphorylation of an aspartyl residue followed by hydrolysis of the aspartylphosphate through a series of "conformational energy state" of the pump molecule relative to its substrates.

The potassium channel

The potassium channel consists of four subunits.

Membrane channels are targets for plant and animal toxins (scorpion toxin for K-channel).

The potassium channel is highly specific for K⁺, The channel environment mimics the water molecules that K⁺ is normally surrounded by.

Potassium permeability

[K⁺]_i is high, so there is a tendency for K⁺ to move out of the cell, but this is counterbalanced by the electric potential which opposes the movement of positive charges out of the cell, as this would accentuate the voltage difference across the cell. An equilibrium is reached when the rate of inward movement of K⁺ ions down the electrochemical gradient equals the rate of outward movement down the concentration gradient. Thus the electrical imbalance caused by the sodium pump will not quite be compensated by K⁺ movement. The end result is a membrane potential, with a voltage difference across the membrane (inside negative). This is important for signalling in nerves, muscles, etc

The electrochemical potential

The Na⁺-K⁺ pump exchanges 3 Na⁺ ions from inside the cell for two K⁺ ions on the outside.

There are two consequences:

Ionic gradients are created: less Na⁺ and more K⁺ inside the cell than outside.

A charge gradient is created, as more positive charges are pushed out than are coming in.

This results in the inside of the cell being at a more negative potential than the outside.

The Nernst equation:

$$E_x = \frac{RT}{zF} \ln \frac{[X]_o}{[X]_i} \cong 58 \log \frac{[X]_o}{[X]_i}$$

Where E is the membrane potential in V (A-level physics?)

R = Gas constant, 8.135 J K⁻¹ mol⁻¹

F = Faraday's constant, 9.684 x 10⁴ C mol⁻¹

T = absolute temperature, -273 °C,

At 25°C, T=298

Z = valence of the ion, 1 for Na⁺

What is the membrane potential at 25 °C for:

[K⁺]_i = 166 mM and [K⁺]_o = 5 mM

The membrane potential:

$$E_M = \frac{RT}{F} \ln \frac{P_{Na} [Na]_o + P_K [K]_o + P_{Cl} [Cl]_i}{P_{Na} [Na]_i + P_K [K]_i + P_{Cl} [Cl]_o}$$

Where P_x is the permeability of the membrane to a particular ion.

Action potentials cause a massive influx of Na^+ in the cell, which must then use metabolic energy to reinstate the membrane potential.

The membrane potential of a nerve or a muscle cell at rest is about -80 mV

Specific ion pumps

There are specific pumps for Na^+ , Ca^{2+} and H^+ , which use ATP hydrolysis to provide the energy.

Some pumps can work in reverse and generate ATP from an ion gradient, e.g. the F1-ATPase in mitochondria.

Other mechanisms exist for other substances that need to cross the membrane

The Neuromuscular junction

The Neuromuscular junction or synapse is a highly complex structure involving pre- and post-synaptic membranes, pre-synaptic vesicles, invagination of the post-synaptic membrane, receptors and enzymes.

Glucose transport

Glucose is membrane-impermeant.

Glucose moves down the concentration gradient into the cell

Glucose binds to a specific glucose transporter which functions by a flip-flop mechanism

The transport is 'facilitated' and makes use of the sodium gradient

Several different proteins. Some are insulin-sensitive

Other transport mechanisms:

Pinocytosis: engulfment by the membrane of extracellular solute and small molecules which end up in small intracellular membrane-bound vesicles

Phagocytosis: engulfment by the membrane of extracellular objects such as bacteria, cell debris, other cells. Again these end up in intracellular membrane-bound vesicles

Exocytosis: Movement of proteins and other molecules (e.g. hormones, blood clotting factors) from intracellular vesicles towards the extracellular space by fusion with the cell membrane.

Cell signalling:

It is not only substances that need to cross membranes. Signals need to cross membranes too.

Some use exocytosis, e.g. hormones.

Others use lipid-soluble molecules that cross membranes.

But other signals rely on trans-membrane receptors.

Here, two mechanisms are common:

1. Gating of ion channels
2. receptor-mediated signalling, immunology

METABOLISM 1

Introduction to protein structure

James Pease (Leukocyte Biology, NHLI)

j.pease@imperial.ac.uk

- Outline the reaction by which amino acids are joined together.
- Appreciate the different types of bond that combine to stabilise a particular protein conformation.
- Sketch a trimeric peptide, illustrating the amino -terminus, carboxyl terminus and side chains.
- Distinguish between a α -helix and a β -pleated sheet and appreciate the bonds that stabilise their formation.
- Understand the concepts of primary structure, secondary structure, tertiary structure & quaternary structure with respect to proteins.
- Outline how warfarin works with reference to the post translational modification of glutamate.

Anatomy of an Amino Acid

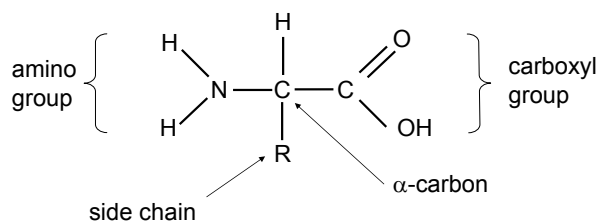

Substitutions at the R position or side chain, give rise to the 20 different amino acids e.g. R=CH₃ in alanine.

The whole of the amino acid minus the side chains is known as the backbone.

Chirality

The central C α carbon atom is a chiral centre (from the Greek, meaning "handed") i.e. it has four different substituents bound to it.

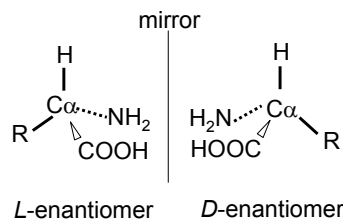

This gives rise to optical isomers (*enantiomers*) of each amino acid each of which is a mirror image of the other.

Glycine (Gly) has no side chain (only an H atom) and is therefore the only non-chiral amino acid.

Individual amino acids (R1 and R2) are joined in condensation reactions (i.e. water is lost) to form peptide chains.

Anatomy of a Peptide

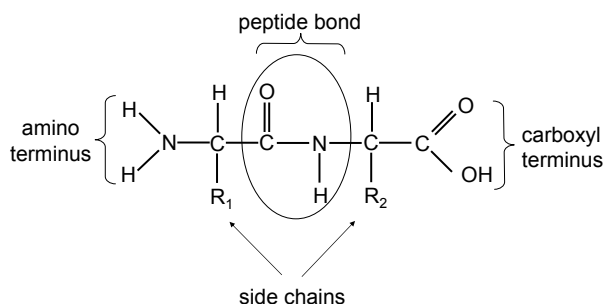

The polypeptide chain of a protein rarely forms a disordered structure (random coil) as proteins generally have functions to fulfil, and these functions rely upon specificity. In turn, functionality requires a definite 3D structure or **conformation** of the polypeptide chain.

Proteins generally possess a degree of flexibility necessary for function e.g. muscle fibres

Proteins are held together by:

Covalent bonds (in which two atoms share electrons) are the strongest bonds within protein and exist in the primary structure itself. Covalent bonds can also exist as *disulphide bridges*. These occur when cysteine side chains within a protein are oxidised resulting in a covalent link between the two amino acids.

Hydrogen Bonds occur when two atoms bearing partial negative charges share a partially positively charged hydrogen, the atoms are engaged in a hydrogen bond (H-bond).

Ionic interactions arise from the electrostatic attraction between charged side chains e.g. Glu, Asp, Lys and Arg. They are relatively strong bonds, particularly when the ion pairs are within the protein interior and excluded from water.

Van der Waals Forces are transient, weak electrostatic attractions between two atoms, due to the fluctuating electron cloud surrounding each atom which has a temporary electric dipole. Although relatively weak and transient in nature, because of the sheer number of these interactions within a protein, they can still have a large part to say in the overall conformation of a protein.

Hydrophobic Interactions are a major force driving the folding of proteins into their correct conformation. They juxtapose hydrophobic side chains by packing them into the interior of the protein. This creates a hydrophobic core and a hydrophilic surface to the majority of proteins

Primary structure is the linear sequence of amino acids that make up the protein.

Secondary structure is defined as local structural motifs within a protein, e.g. α -helices and β -pleated sheets.

Tertiary structure is the arrangement of the secondary structure motifs into compact domains.

Quaternary structure is the three dimensional structure of a multimeric protein composed of several subunits

Primary structure

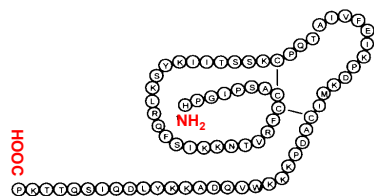

Secondary structure (e.g. α -helix)



Tertiary structure

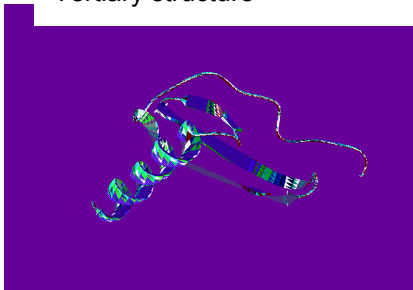

Quaternary structure

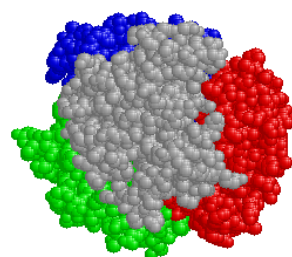

Even after synthesis, (**post translation**) the starting set of 20 amino acids can be modified to create novel amino acids, enhancing the capabilities of the protein e.g. hydroxylation, glycosylation, carboxylation.

NUCLEIC ACIDS AND GENE EXPRESSION 1

Nucleic acids and chromosomes

Dr. Birgit Leitinger

Nucleic Acids

- DNA and RNA are nucleic acids.
- They are macromolecules made up of a large number of nucleotides.
- A nucleotide is composed of a base, a sugar, and a phosphate group.
- A nucleoside is composed of a base and a sugar (no phosphate).
- The sugar in DNA is deoxyribose, the sugar in RNA is ribose.

Nucleotide: deoxyadenosine 5'-triphosphate (dATP)

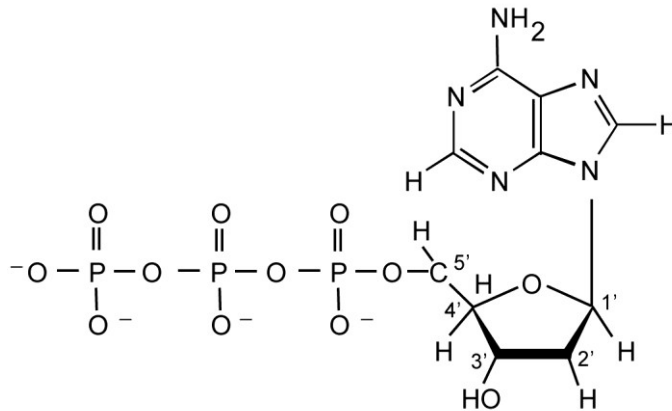

DNA and RNA bases:

Pyrimidines:

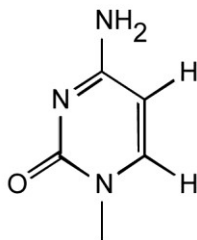

Cytosine
(C)

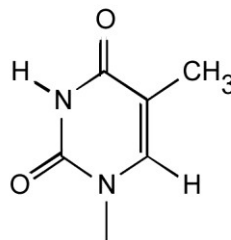

Thymine
(T)
DNA only

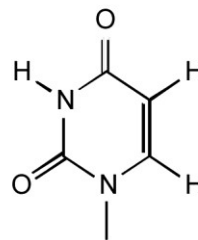

Uracil
(U)
RNA only

Purines:

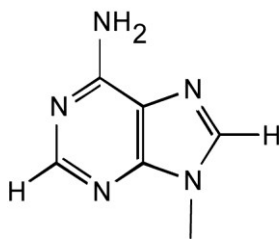

Adenine
(A)

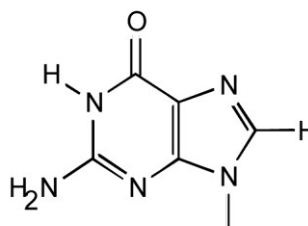

Guanine
(G)

The nucleosides: (deoxy)cytidine, (deoxy)thymidine, (deoxy)uridine, (deoxy)adenosine, (deoxy)guanosine

The nucleotides: deoxyadenosine 5'-triphosphate (dATP); adenosine monophosphate (AMP) etc.

A single DNA chain

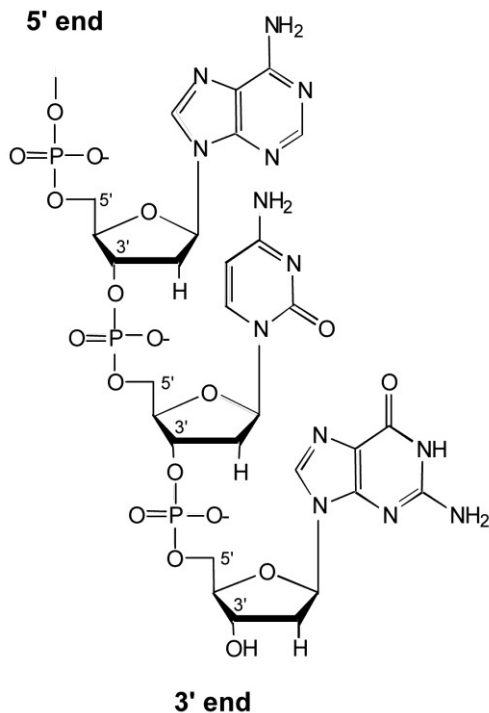

The DNA double helix

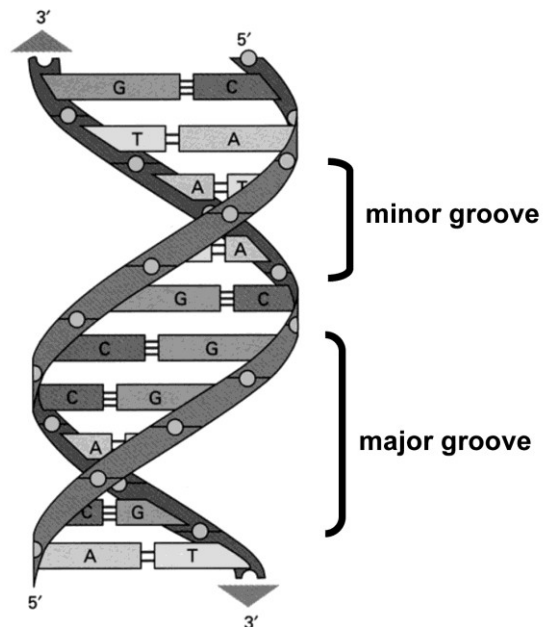

- **DNA** is a long chain of deoxyribose units linked by phosphodiester links.
- The phosphate on the 5' carbon is linked to the –OH on the 3' carbon along the chain.
- On each deoxyribose there is a base.
- The chain has two ends. The 5' end and the 3' end. It is not symmetrical.
- The primary sequence is the linear sequence of the bases. By convention, the nucleotide sequence is specified in the 5' to 3' direction.
- **The secondary structure** of DNA is a right-handed double helix. The two chains in the helix run in opposite directions.
- The deoxyribose and phosphate groups run along the outside of the helix, with the negative charges outside.
- The bases point inwards and the flat planes are perpendicular to the helix.
- The two chains are held together by hydrogen bonds between the bases.
- The two strands are complementary in their sequence due to the specificity of base-pairing. Adenine always pairs with Thymine; Guanine always pairs with Cytosine.

Watson-Crick base pairs

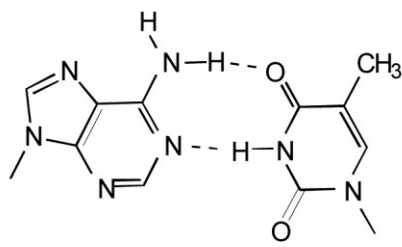

Adenine
(A)

Thymine
(T)

2 hydrogen bonds
→ less stable

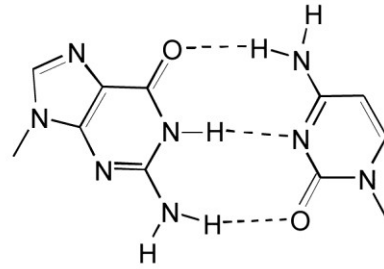

Guanine
(G)

Cytosine
(C)

3 hydrogen bonds
→ more stable

Melting and re-annealing

- High temperature and/or low salt concentration causes the two strands to melt or disassociate.
- If you then lower the temperature or increase the salt concentration, the two melted strands will re-anneal into a double helix.
- Hybridisation: in a mixture of DNA with different sequences, the complementary strands will find each other in the mixture.

The *E. coli* genome:

- *E. coli* has 4.7×10^6 base pairs in a single circular double-stranded molecule.
- The length of the *E. coli* DNA is 1.4 mm.
- The DNA in *E. coli* is tightly packaged – the bacterium is only 3 μm long.

The human genome:

- The human genome (haploid) consists of about 3×10^9 base pairs of DNA.
- The DNA is divided into chromosomes that each contain a linear double-helical DNA molecule of about 200×10^6 base pairs.
- Prior to cell division, the DNA condenses into discrete chromosomes, visible by microscopy.
- A diploid cell has 46 chromosomes; 22 pairs of 'normal' chromosomes and 2 sex chromosomes.

Packaging of eukaryotic DNA:

- The DNA in a diploid human cell is nearly 2 m long. To fit into cells, the DNA is tightly packaged into chromatin.
- Chromatin consists of DNA and proteins.
- The lowest level of packaging is the nucleosome, which consists of DNA wrapped around histone proteins.
- The nucleosomes form a chain, which pack into a helical array.

A nucleosome

8 histones: 2 each of 2A, 2B, 3 and 4

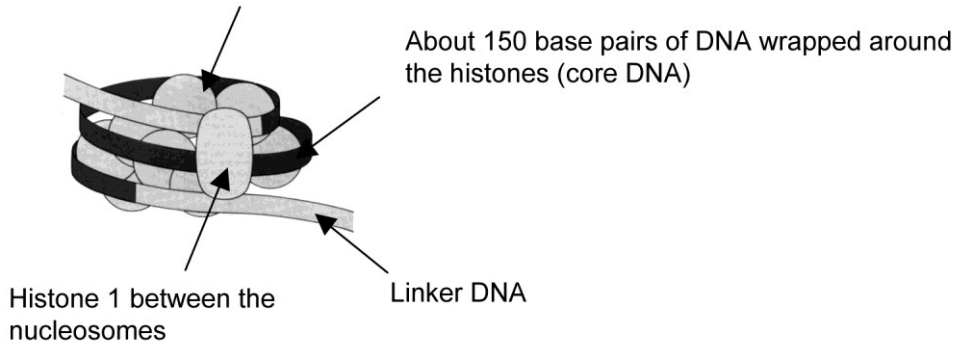

Packaging of DNA into a chromosome

As the DNA has already replicated, there are two identical copies and two identical chromatids (sister chromatids) for each chromosome at metaphase.

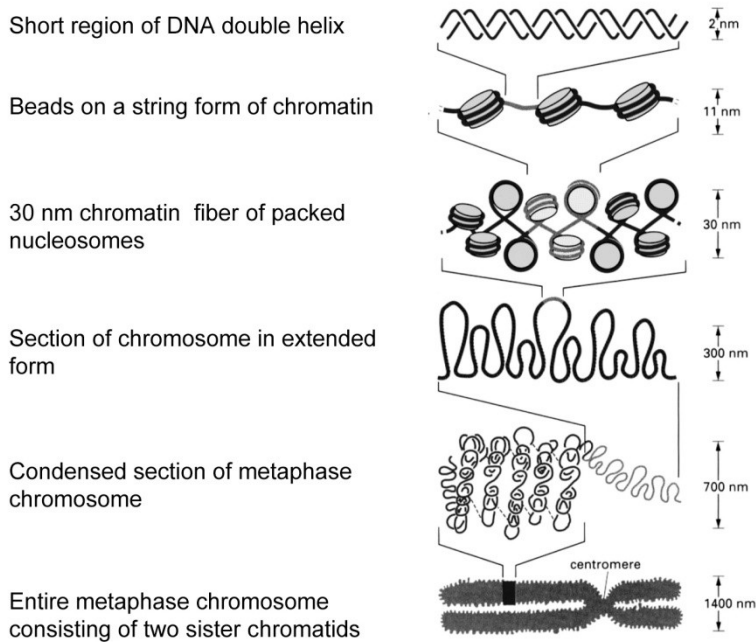

Net result: each DNA molecule has been packaged into a mitotic chromosome that is 10 000 fold shorter than its extended length

INTRODUCTION TO CELLS 4

Blood and Blood cells

Dr Michael Emerson (m.emerson@imperial.ac.uk)

Learning objectives

- List the main functions of the blood.
- List the major components of blood.
- Explain the importance, basic structure and role of haemoglobin
- Describe the essential features of the erythrocyte and list its major functions
- Define anaemia and list the major causes and subclasses
- Relate the types of anaemia to red blood cell volume
- Explain simply the major functions of leukocytes and platelets
- Explain simply the concepts of immune responses and passive immunity
- List the major functions of plasma

Main Functions of Blood

- Transport
- Heat distribution
- Immunity
- Haemostasis
- Support
- MAINTAIN HOMEOSTASIS

Erythrocytes

- Transport oxygen and CO₂
- Biconcave disc
- No organelles
- 120 day lifespan
- Removed by macrophages
- Dependent on dietary iron

Haemoglobin

- 4 polypeptides and a haem group
- Haem contains ferrous iron
- Carries oxygen
- Carries CO₂ in conjunction with carbonic anhydrase

Erythrocyte Production

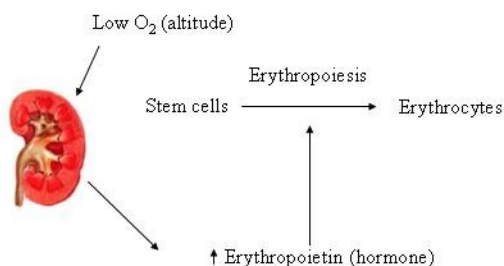

Key red cell parameters

Concⁿ haemoglobin (13.5-16.5♂; 11.5-14.5 ♀ g/dl)
 Red cell count ($5.4 \times 10^{12}/l$ (♂) and $4.8 \times 10^{12}/l$ (♀)
 Haematocrit (packed cell volume): 0.40-0.54 (♂)
 0.35-0.47 (♀)

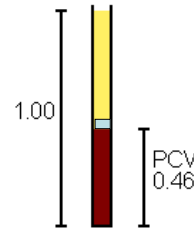

Derived indices	Normal
MCV mean cell volume	82-99fl
MCH mean cell haemoglobin	27-33pg
MCHC mean cell haemoglobin concentration	32-34g/dl

Anaemia

“Deficit in haemoglobin concentration”

Mechanisms

Microcytic (small MCV)
 Fe deficiency: menstruation
 GIT lesions or cancers

Normocytic (normal MCV)

Acute blood loss

Macrocytic (large MCV)

Vit B12 deficiency: pernicious anaemia

Folic acid deficiency: pregnancy

Leukocytes

- Granulocytes: Neutrophils (phagocytic)
 Eosinophils (allergy)
 Basophils (produce heparin)
- Lymphocytes (antibody producing)
- Monocytes (phagocytic)

T-lymphocytes

Cellular immunity

Become *immunologically competent* through acquisition of surface antigenic molecules in thymus

Foreign antigens cause blast transformation which produces progeny expressing these surface receptors

Activated lymphocytes produce *chemotaxins*
 lymphotoxin
 interferon

Subgroups include: Suppressor cells
 Helper cells

B-lymphocytes

Humoral immunity

Exposure to foreign antigen leads to immunoglobulin (antibody) production

Various types of antibody with different functions

Primary response: occurs after a latent period, peak then fall

Secondary response: greater, quicker and longer due to memory cells (long lived B-lymphocyte)

Passive immunity: acquired immunity from injected antibody or placenta or colostrum (not human)

Antigen-antobody reactions: assist phagocytosis: precipitation
 agglutination
 opsonisation
 neutralisation

Monocytes

Appear later

Become macrophages in tissue

“Big eaters”

Stimulate repair

Ingest, store and modify antigens, present to lymphocytes

Normal leukocyte count

Total $3.5 - 7.5 \times 10^9/L$

Neutrophils 2.5 - 7.5 (40 - 75%)

Eosinophils 0.04 - 0.4 (1 - 6%)

Basophils 0.01 - 0.1 (<1%)

Monocytes 0.2 - 0.8 (2 - 10%)

Lymphocytes 1.5 - 4.0 (20 - 45%)

Platelets

- Many organelles but no nuclei
- Granules
- Surface receptors initiate activation e.g. collagen and thrombin
- Adhere to exposed collagen
- Release granules to recruit and activate platelets
- Clot formation

Functions of Plasma

Fluid component of blood which acts as carrier for cells and key components:

Nutrients	Glucose, Lipids, Amino acids
Hormones	Thyroxine, Cortisol, Erythropoietin
Proteins	Clotting factors, Albumin, Globulins
Inorganic ions	Na, K, Ca, PO_4 , HCO_3
Products of metabolism	Urea, Lactic acid

METABOLISM 2

Energetics and enzymes

James Pease (Leukocyte Biology, NHLI)

j.pease@imperial.ac.uk

- Explain the concept of free energy and how we can use changes in free energy to predict the outcome of a reaction.
- Draw the chemical structure of ATP and explain how it acts as a carrier of free energy and is used to couple energetically unfavourable reactions.
- Describe how enzymes act as catalysts of reactions with reference to the reactions catalysed by lysozyme and glucose-6-phosphatase.
- Outline the differences between lock and key and induced fit models of substrate-enzyme interactions.
- Describe graphically, the effects of substrate concentration, temperature and pH on reactions catalysed by enzymes.
- Illustrate the role of the coenzyme NAD in the reaction catalysed by lactate dehydrogenase.

The First Law of Thermodynamics

Energy can neither be created nor destroyed. i.e. it is simply converted from one form to another.

The Second Law of Thermodynamics

In any isolated system, e.g. a single cell or the universe, the degree of disorder can only increase. The amount of disorder in a particular system can be quantified as its **entropy**. Reactions proceed spontaneously towards products with greater entropy (i.e. more disorder).

However, biological systems are very well ordered. This is achieved by investing taking energy from the environment surrounding the cell and investing it in chemical reactions which maintain order.

The free energy function combines both the 1st and 2nd Laws of thermodynamics. Changes in Gibbs' Free Energy (ΔG) measure the amount of disorder that results from a particular reaction.

A reaction can only occur spontaneously if ΔG **is negative**. Conversely, a reaction cannot occur spontaneously if ΔG for the reaction **is positive**.

Pathways within the cell that synthesise molecules are generally energetically unfavourable e.g. peptide synthesis. They take place because they are coupled to an **energetically favourable** one. Providing that the sum of the ΔG for the overall reaction is still negative, the reaction will proceed.

The majority of energetically unfavourable biochemical reactions rely on the hydrolysis of

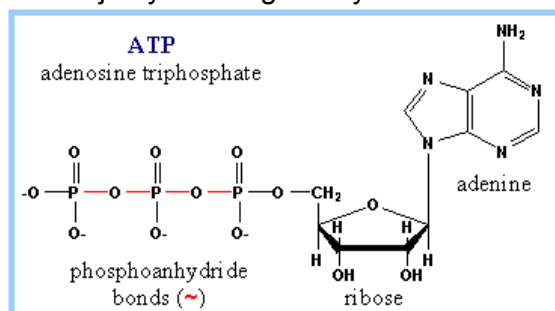

high-energy phosphate bonds such as those found in ATP.

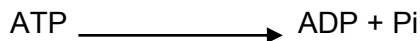

$\Delta G^{\circ} = -31 \text{ kJ/mol} !!!$

(ΔG° = standard free energy change at pH 7)

In a biological setting, most energetically favourable reactions will not occur at a rate useful for life, *unless* catalysed by enzymes. Enzymes function by lowering the barriers that block a particular reaction. e.g. Barrier dam analogy, Alberts Essential Cell biology page 93.

Enzymes bind one or more substrate molecules tightly within a part of the protein known as the **active site**. Enzymes arrange the substrate(s) in such a way that certain bonds are strained. Key residues within the enzyme participate in either the making or breaking of bonds by altering the arrangement of electrons within the substrate(s).

This can often take the form of either **oxidation reactions**, (in which electrons are removed from a molecule) or **reduction reactions** (in which electrons are added to a molecule). Since the cellular environment is generally aqueous, often, when a molecule gains an electron, it also simultaneously gains a proton.

The **transition state** is the particular conformation of the substrate in which the atoms of the molecule are rearranged both geometrically and electronically so that the reaction can proceed. Enzymes work by bending their substrates in such a way that the bonds to be broken are stressed and the substrate molecule resembles the transition state. This makes them more amenable to reaction with other molecules.

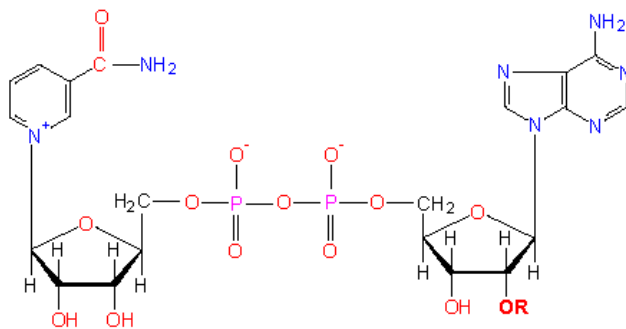

NAD⁺ (Nicotinamide adenine dinucleotide) is a vital component of many dehydrogenation reactions within the body. It can be described as a co-enzyme as it has no catalytic activity of its own and functions only after binding to an enzyme.

NAD⁺ helps to catalyse the dehydrogenation of substrates by readily accepting a hydrogen atom and two electrons.

The reaction rates of enzymes vary considerably and can be measured experimentally. K_M is known as the Michaelis Constant and is defined as the concentration of substrate at which a particular enzyme works at half its maximal velocity. Biochemically, the K_M value is useful as a means of comparing the strength of Enzyme-Substrate complexes.

Generally a low K_M indicates tight binding of a substrate to an enzyme. Conversely, a high K_M is indicative of weak binding. You will learn how to derive the parameter K_M in **practical B3**, by the construction of a double-reciprocal plot of $1/V$ against $1/[S]$ (*Lineweaver-Burk Plot*).

At V_{max} (maximal rate of reaction) the rate of product formation depends only on one thing: How rapidly the substrate can be processed. This is known as the turnover number.

NUCLEIC ACIDS AND GENE EXPRESSION 2

DNA replication, the cell cycle and mitosis

Dr Birgit Leitinger

DNA replication

- DNA replication is semi-conservative. Each strand forms the template for a new strand of DNA.
- DNA polymerases add deoxynucleotide tri-phosphates to the 3' end of a DNA molecule.
- Synthesis is driven by the release of energy from the hydrolysis of the tri-phosphate.
- DNA polymerases need a template and a primer. They cannot start a new chain from scratch.

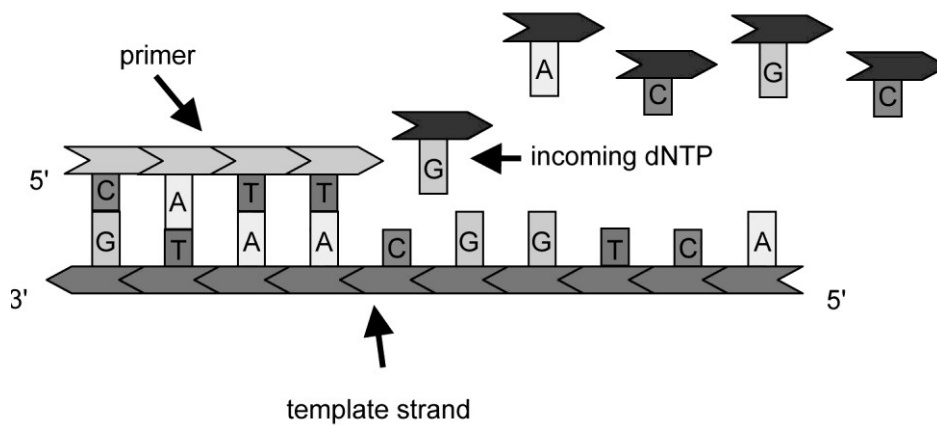

Enzyme reaction

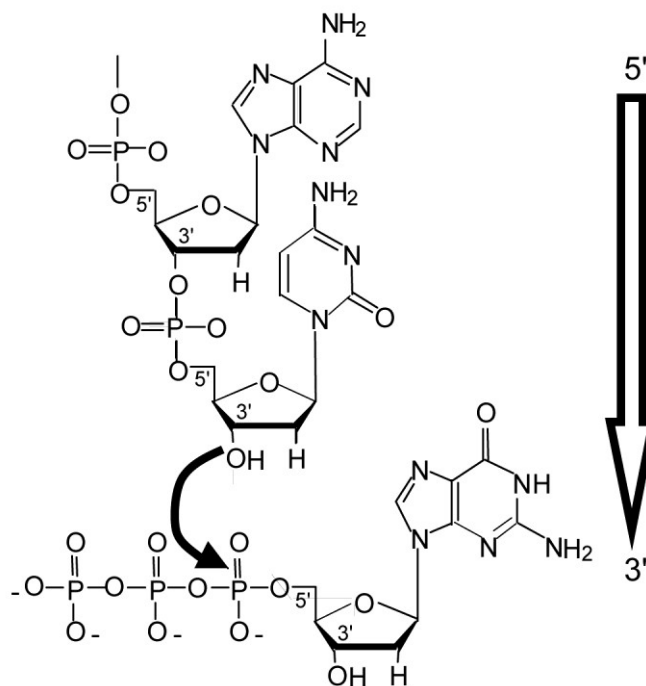

Some nucleoside analogs used as drugs

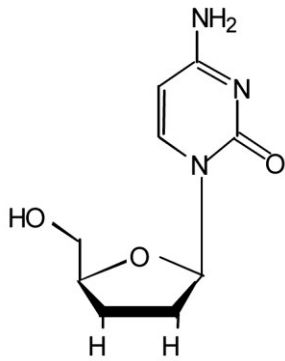

dideoxycytosine (ddC)
Drug for HIV (zalcitabine)

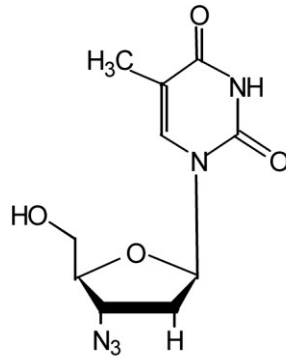

azidothymidine (AZT)
Drug for HIV (Zidovudine)

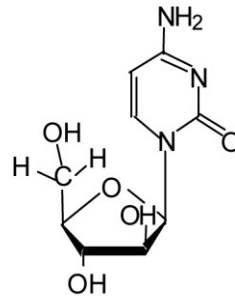

Cytosine arabinoside
Used in Chemotherapy

DNA Replication

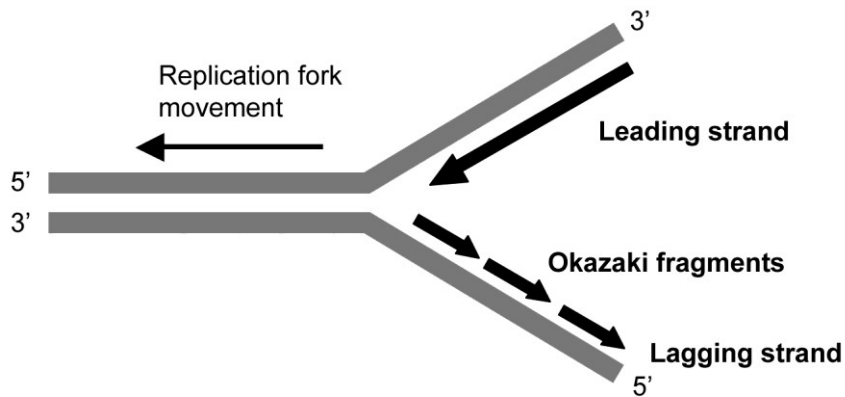

- Replication begins at discrete points on the DNA molecule and proceeds bi-directionally. The structure formed is called a replication fork.
- The replication fork is asymmetric. Both strands are synthesised in 5' to 3' direction.
- DNA synthesis is continuous on the leading strand
- On the lagging strand, synthesis is discontinuous.
- As the replication fork moves forward, single-stranded DNA is exposed on the lagging strand.
- When about 100-200 bases are exposed, a short RNA primer of about 5-10 bases is synthesised.
- The primer is synthesised by an RNA polymerase called primase.
- The primer is extended by a DNA Polymerase until the last RNA primer is reached.
- The stretches of DNA synthesised on the lagging strand are called Okazaki fragments.

Joining the Okazaki fragments

A special ribonuclease removes the RNA primer using a 5' to 3' exonuclease activity. DNA polymerase then synthesises DNA through the RNA primer region. DNA ligase joins the two adjacent strands of DNA together using ATP.

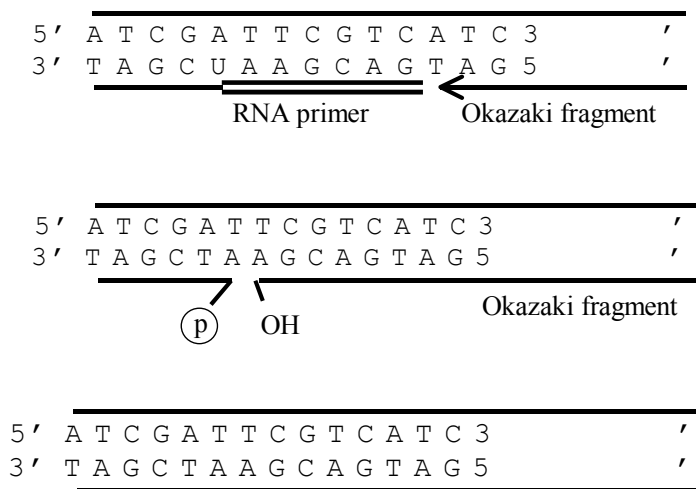

Accuracy of DNA replication

- DNA replication has an error frequency of about 1 change per 10^9 base pairs.
- Proof reading: DNA Polymerase has 3' to 5' exonuclease activities for proof reading.
- RNA Primers: Inaccurate RNA primers are replaced by accurate DNA.

Replication of the *E. coli* chromosome

In *E. coli* there is a single replication origin and the two forks meet on the other side of the circular chromosome.

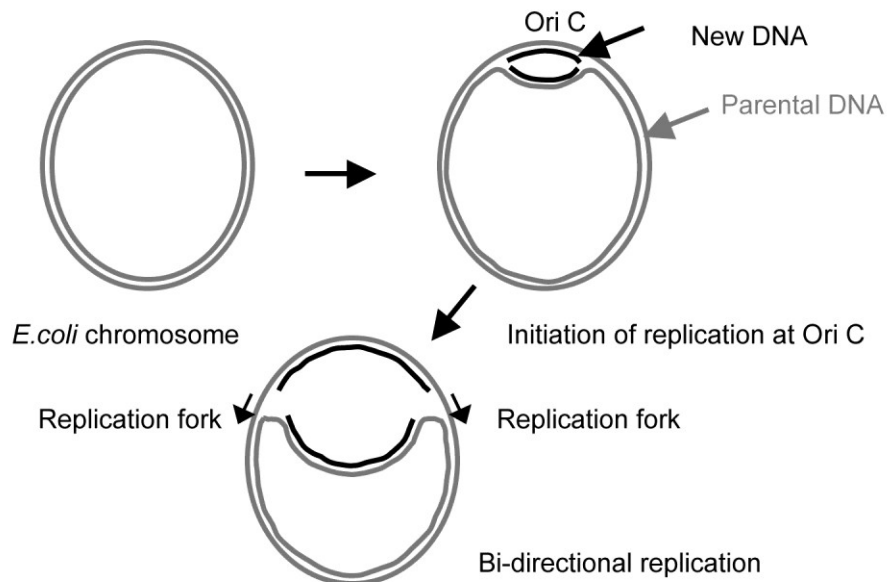

Replication of the eukaryotic genome

The enzymatic mechanism of replication in eukaryotes is very similar to that in *E. coli*. There are replication forks, leading and lagging strands and enzymes which carry out all the same functions as in *E. coli*, but the actual proteins used are different.

Multiple replication origins in eukaryotes

- Eukaryotic chromosomes are linear and very long.
- Multiple replication origins are distributed at intervals of about 100 kb.
- Each replication origin gives bidirectional replication forks.
- Replication is finished when all the forks have met.

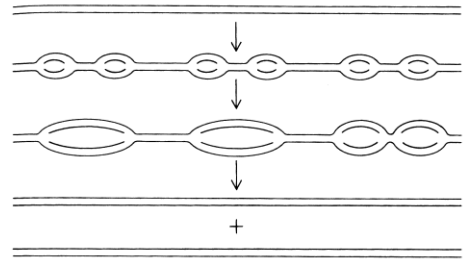

The mammalian cell cycle

A mammalian cell cycle takes about 24 hours in tissue culture.

M phase: Mitosis 1 hr; cell division, metaphase.

G1; gap phase 1; 10 hrs

S phase; DNA replication, 9 hrs

G2; gap phase 2; 4 hrs

G0; cells which have stopped dividing.

G1, G0, S and G2 are interphase.

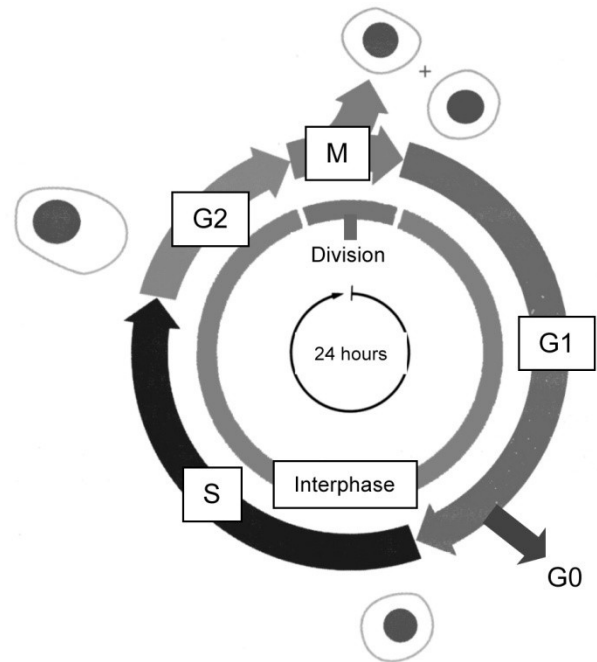

Metaphase and Anaphase of Mitosis

Metaphase

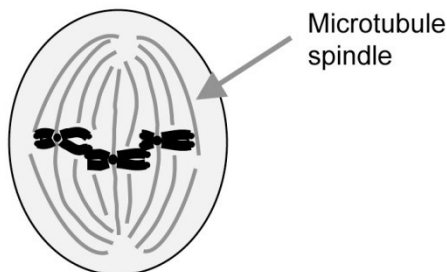

Condensed chromosomes, aligned on central plane of spindle

Anaphase

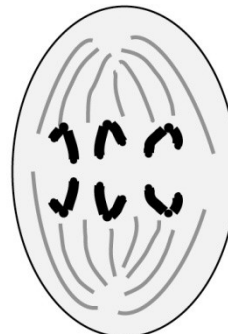

Sister chromatids move to opposite poles of spindle

METABOLISM 3

Metabolic pathways and ATP production I

James Pease (Leukocyte Biology, NHLI)

j.pease@imperial.ac.uk

- Sketch a cartoon of the three stages of cellular metabolism that convert food to waste products in higher organisms, illustrating the cellular location of each stage.
- Outline the metabolism of glucose by the process of glycolysis, listing the key reactions, in particular those reactions that consume ATP and those that generate ATP.
- Distinguish between the aerobic and anaerobic metabolism of glucose with reference to the enzymes involved and the comparative efficiencies of each pathway with respect to ATP generation.
- Describe the reactions catalysed by lactate dehydrogenase and creatine kinase and explain the diagnostic relevance of their appearance in plasma.
- Outline the oxidative decarboxylation reaction catalysed by pyruvate dehydrogenase, with reference to the product and the five co-enzymes required by this enzyme complex.

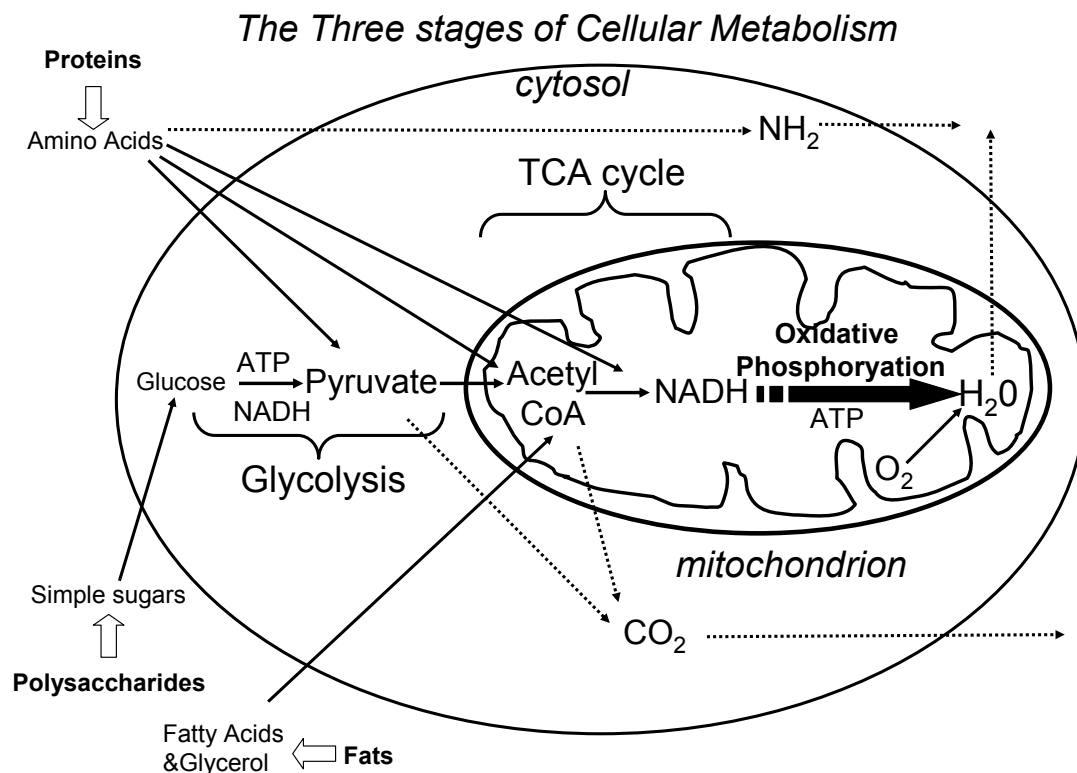

Glycolysis is central to metabolism and is essentially an anaerobic process, occurring in the cytoplasm of cells and is probably a throwback to the pathways used by prehistoric anaerobic bacteria. Within the ten reactions that make up the glycolysis pathway, there are **two main concepts**: the formation of a high energy compound and its subsequent splitting.

The first step (i) involves the investment of energy in the form of ATP whereas the second produces useful energy in the form of ATP generation. Overall the reaction takes **One** 6 carbon molecule (Glucose) and generates **two** three carbon molecules (Pyruvate). In doing so, ATP and NADH are produced (covered in detail in Alberts Essential Cell biology page 430).

Substrate-level phosphorylation can be defined as the production of ATP by the direct transfer of a high-energy phosphate group from an intermediate substrate in a biochemical pathway to ADP, such as occurs in glycolysis. This is in contrast to oxidative phosphorylation, where ATP is produced using energy derived from the transfer of electrons in an electron transport system (Lecture 5).

Pyruvate generated in glycolysis has three possible fates including alcoholic fermentation (yeasts) and the generation of lactate under the control of the enzyme ***lactate dehydrogenase***. This process is ***anaerobic*** and is characteristic of mammalian muscle during intense activity when oxygen is a limiting factor. It allows NAD^+ to be regenerated and thus glycolysis to continue, in conditions of oxygen deprivation. i.e. conditions in which the rate of NADH formation by glycolysis is greater than its rate of oxidation by the respiratory chain. NAD^+ , you recall, is needed for the dehydrogenation of glyceraldehyde 3-phosphate, which is the first step in generating ATP for the body (Lecture 2).

Elevated levels of lactate dehydrogenase can be used to diagnose several disorders including stroke and myocardial infarction. Similarly, blood levels of the enzyme ***creatine kinase*** which buffer demands for phosphate in working muscle can be used as a diagnostic aid.

The third fate of pyruvate generated from glycolysis is the generation of acetyl CoA which occurs in the mitochondria of cells.

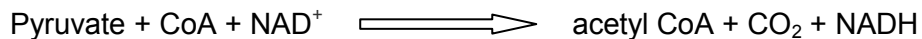

The acetyl CoA thus formed is committed to entry into the citric acid cycle and can ultimately produce ATP by the process of *oxidative phosphorylation* (lecture 5). The reaction is catalysed by the ***pyruvate dehydrogenase complex*** which consists of ***three*** individual enzymes and also ***five*** co-factors. Some of these co-factors are a permanent part of the enzyme complex and are known as prosthetic groups

e.g. ***Pyruvate Decarboxylase*** has the prosthetic group ***thiamine pyrophosphate (TPP)***

Lipoamide Reductase Transacetylase has the prosthetic group ***Lipoamide***

Dihydrolipoyl Dehydrogenase has the prosthetic group ***FAD (Flavine Adenine Dinucleotide)***

Overall, the enzyme has four steps;

- (i) Decarboxylation of pyruvate to give hydroxyethyl TPP (PD & TPP).
- (ii) Oxidation & transfer to lipoamide to give acetylipoamide (LRT)
- (iii) Transfer of the acetyl group to CoA to give acetyl CoA (LRT & CoA).
- (iv) Regeneration of oxidised lipoamide (DD, FAD, NAD^+)

A nice animated reaction can be seen at:

<http://www.rpi.edu/dept/bcbp/molbiochem/MBWeb/mb1/part2/movies/pyrdeh.dcr>

Acetyl CoA can also be generated from fatty acids via a sequence of dehydration, hydration, oxidation and thiolysis reactions (***collectively called β -oxidation***) resulting in production of one molecule of acetyl CoA and an acyl CoA species which is 2 carbons shorter than the original. From just 7 β -oxidation reactions, the 16-carbon palmitoyl CoA molecule produces 8 molecules of acetyl CoA. Hence fatty acid oxidation yields several times the usable chemical energy that carbohydrates can deliver, making them compact fuels for the body's energy requirements.

The ***transamination*** of amino acids can also generate useful metabolites. These reactions can be 'separated' into pathways depending on the number of carbon atoms the amino acid possesses. e.g. C3 family alanine, serine (glycine), and cysteine are all degraded to pyruvate which can undergo glycolysis.

NUCLEIC ACIDS AND GENE EXPRESSION 3

Gene Organisation & Transcription Part 1 - Gene Transcription

Dr Laki Buluwela (l.buluwela@imperial.ac.uk)

Learning Objectives:

- Describe the basic differences between DNA and RNA
- Describe what is meant by “transcription”
- List the major functional classes of RNA and the classes of RNA polymerases involved in synthesising each of these.
- Describe what is meant by a “gene promoter”
- Describe what is meant by a “transcription factor”
- Describe, with the aid of diagrams, the processes involved in transcribing a eukaryotic gene.

What Do We Mean By “Gene Expression” ?



- The initial product of gene expression is always RNA
- In some cases this RNA is functional (e.g. tRNA, rRNA, snRNA)
- In many cases this RNA is the template for protein translation (eg mRNA)
- Gene expression occurs in the cell nucleus. RNA is exported to the cell cytoplasm, to be used in “Protein Translation”

Eukaryotic RNA Polymerases

Eukaryotic cells contain three types of RNA polymerases:

- RNA Polymerase I -Transcribes rRNA genes
- RNA Polymerase III- Transcribes tRNA and 5S RNA genes
- RNA Polymerase II - Transcribes genes encoding proteins into mRNA

Transcription: Making an RNA copy of a DNA strand

3. Ribonucleotide bases are joined by phosphodiester bonds.
The RNA chain grows one base at a time in a 5' ->3' direction

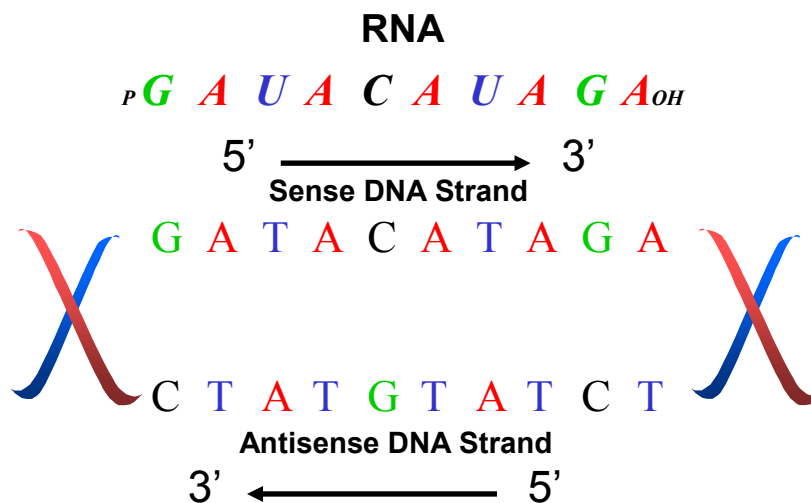

Components of the Basal Transcription Complex

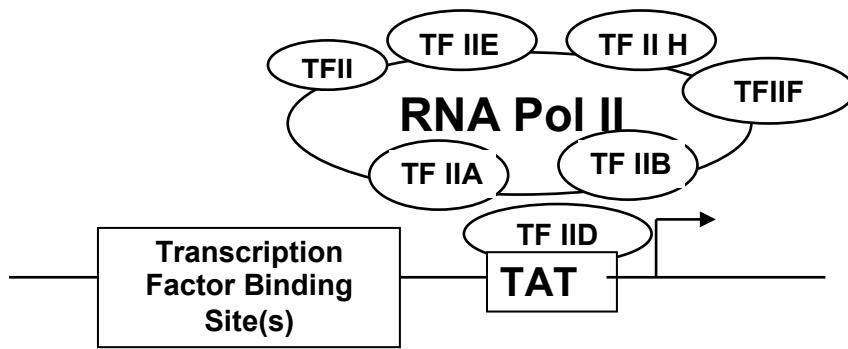

- The **Basal Transcription Complex** allows **RNA polymerase II** to be phosphorylated and then engage in transcription.
- In the absence of binding of other **Transcription Factors** this produces a **Basal** (low) level of transcription.
- Transcription factors “bend DNA” on binding. They can interact with each other and the Basal Transcription Complex to modulate transcription.

METABOLISM 4

Metabolic pathways and ATP production II

James Pease (Leukocyte Biology, NHLI)

j.pease@imperial.ac.uk

- Describe the processes by which the fatty acid palmitate and the amino acid alanine are converted into acetyl-CoA.
- Outline the Krebs or TCA (tricarboxylic acid cycle) with particular reference to the steps involved in the oxidation of acetyl Co-A and the formation of NADH and FADH₂ and the cellular location of these reactions.
- Outline the glycerol phosphate shuttle and the malate-aspartate shuttle, in particular stating why these mechanisms are required.
- Calculate the theoretical maximum yield of ATP per glucose molecule oxidized by aerobic respiration and compare this to the theoretical maximum yield of ATP per molecule of palmitic acid.
- Give two examples of the use of NADPH in reductive biosynthesis.

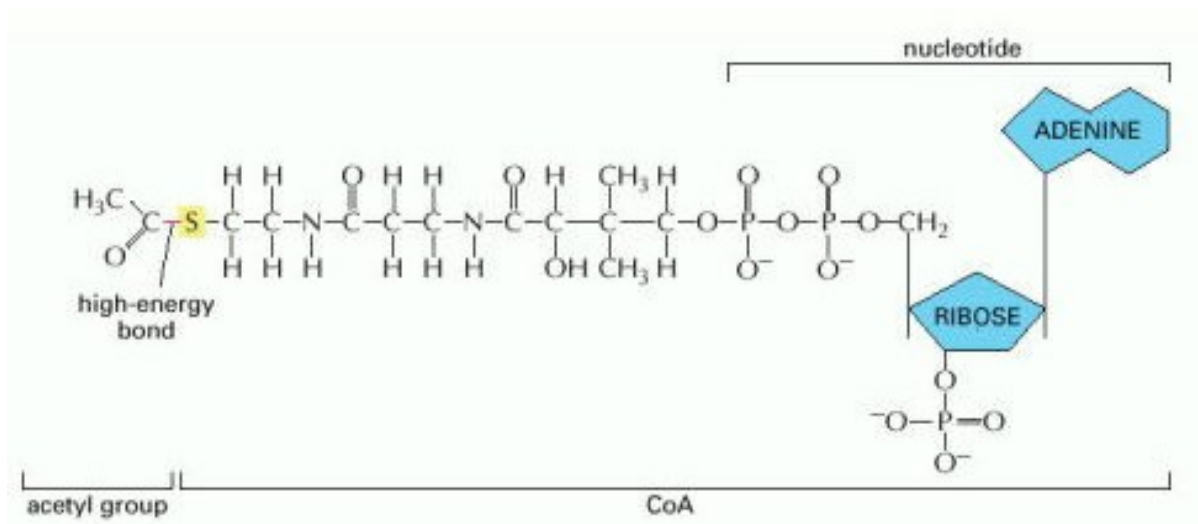

Acetyl CoA (Alberts page 110)

The thioester bond is a high-energy linkage, so it is readily hydrolysed, enabling acetyl CoA to donate the acetate (2C) to other molecules.

RNA ancestry suggests it is of primeval origin.

Krebs cycle

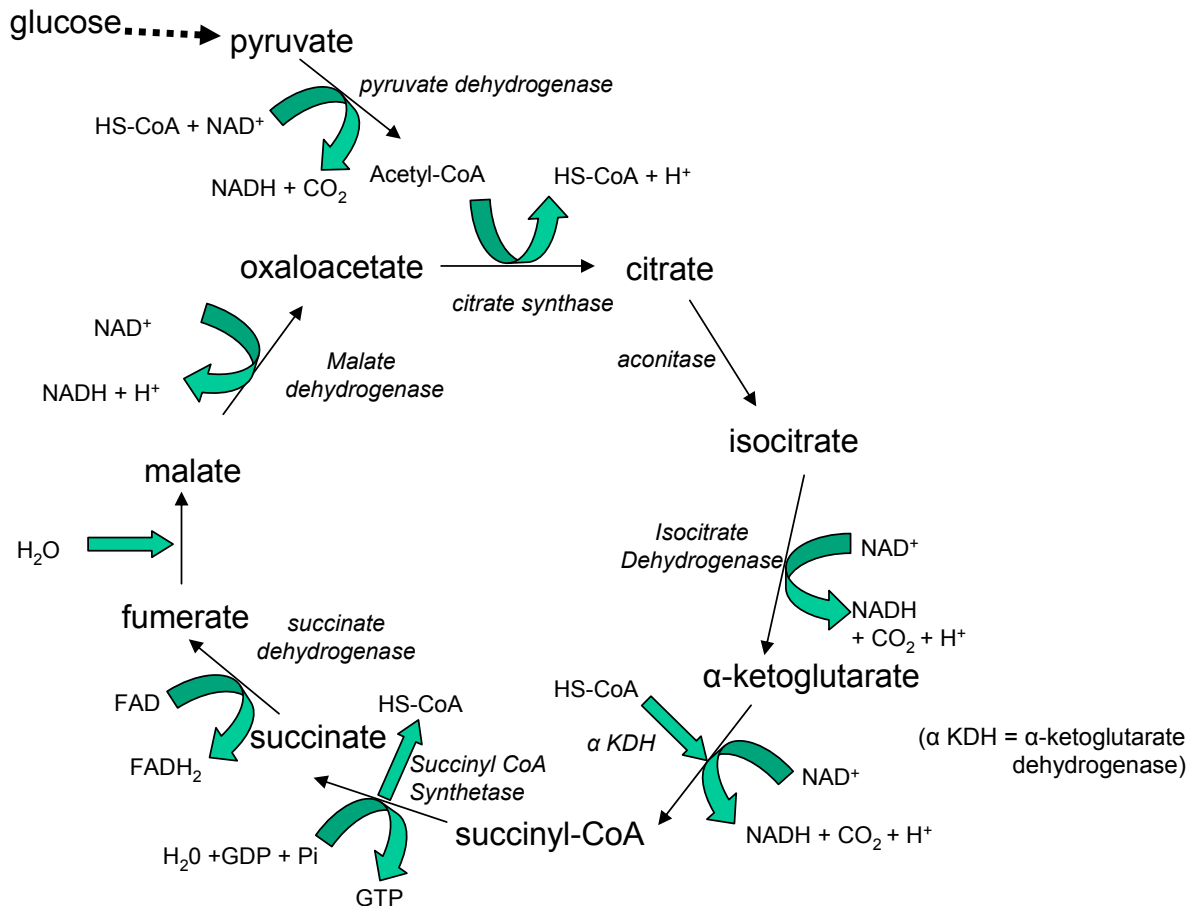

Acetyl CoA can enter the **Krebs Cycle** (a.k.a. the Tricarboxylic Acid (TCA) cycle or the citric acid cycle). This is a continuous cycle of eight reactions, starting with 2 carbon atoms from acetyl Co-A being condensed with the 4 carbon unit of oxaloacetate to give a 6 carbon unit, citrate.

The thio-ester linkage of the acetyl Co-A allows it to be readily donated to oxaloacetate.

The Krebs cycle enzymes are soluble proteins located in the mitochondrial matrix space, except for **succinate dehydrogenase**, which is an integral membrane protein that is firmly attached to the inner surface of the inner mitochondrial membrane. Here, it can communicate directly with components in the respiratory chain. The majority of the energy that derives from the metabolism of food is generated when the reduced coenzymes are re-oxidised by the respiratory chain in the mitochondrial inner membrane in a process known as **oxidative phosphorylation** (lecture 5). The Krebs cycle only operates under aerobic conditions, as the NAD⁺ and FAD needed are only re-generated via the transfer of electrons to O₂ during oxidative phosphorylation.

Re-oxidation of the reduced co-factors NADH and FADH₂ by the process of oxidative phosphorylation yields the following:

Three ATP molecules are formed by the re-oxidation of each NADH molecule.

Two ATP molecules are formed by the re-oxidation of each FADH₂ molecule.

Therefore, from the Krebs Cycle:

1 X acetyl CoA gives 3 x NADH plus 1 x FADH₂ + 1x GTP = 12 ATP

NADH produced in glycolysis needs to enter the mitochondria to be utilised by the process of oxidative phosphorylation and to regenerate NAD^+ . Remember, there is only a finite amount of NAD^+ and unless it is regenerated, glycolysis will very quickly grind to a halt. NADH, or more accurately, its high-energy electrons, cross from the cytosol into the matrix of the mitochondria via the **Glycerol Phosphate Shuttle** and the **Malate-Aspartate Shuttle**.

Glycerol Phosphate Shuttle

Electrons from NADH, rather than NADH itself are carried across the mitochondrial membrane via the carrier glycerol-3-phosphate.

A cytosolic glycerol dehydrogenase (G-DH) transfers electrons from NADH to glycerol 3-phosphate, which can diffuse into the mitochondria. There, a membrane bound form of the same enzyme transfers them to FAD.

Malate-Aspartate Shuttle

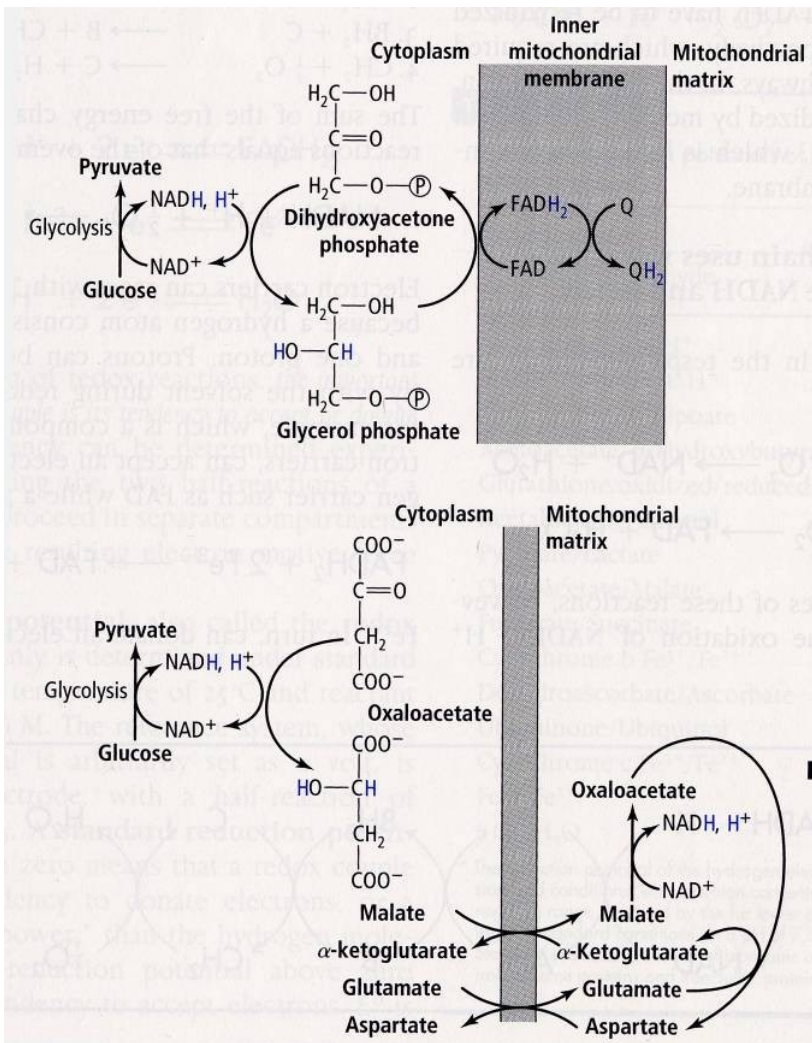

This takes place primarily in the heart and liver and uses two membrane carriers and four enzymes. Hydrogen is transferred from cytoplasmic NADH to oxaloacetate to give malate (catalysed by *malate dehydrogenase*).

A transamination reaction takes an amino group from glutamate and transfer it to oxaloacetate, giving aspartate. This aspartate then crosses the matrix membrane, via an amino acid carrier, and is duly converted by the same transamination reaction in reverse, back to oxaloacetate.

Malate can be transported into the mitochondria where it is rapidly re-oxidised by NAD^+ to give oxaloacetate and NADH.

NADP⁺ (Nicotinamide Adenine Dinucleotide Phosphate)

NADP⁺ is a relative of NAD^+ , differing only by a phosphate group attached to one of the ribose rings. The phosphate group does not participate in electron transfer, but gives it a slightly different conformation, meaning that it will bind to different enzymes than NAD^+ . NADP^+ takes part in **anabolic** reactions, whereas NAD^+ takes place in **catabolic** reactions e.g. biosynthesis of RNA and cholesterol, allowing electron transport in catabolism to be kept separate to that of anabolism.

METABOLISM 5

Mitochondria and oxidative phosphorylation

James Pease (Leukocyte Biology, NHLI)

j.pease@imperial.ac.uk

- Draw a cross sectional representation of a mitochondrion, and label its component parts.
- Outline the proposed evolutionary origins of mitochondria.
- Outline the chemiosmotic theory.
- Describe the electron transport chain in mitochondria with reference to the functions of coenzyme Q (ubiquinone) and cytochrome c.
- Describe how ATP synthase is able to generate and utilise ATP respectively, with reference to its structure.
- Explain why carbon monoxide, cyanide, malonate and oligomycin are poisonous in terms of their effects on specific components of the electron transport chain.

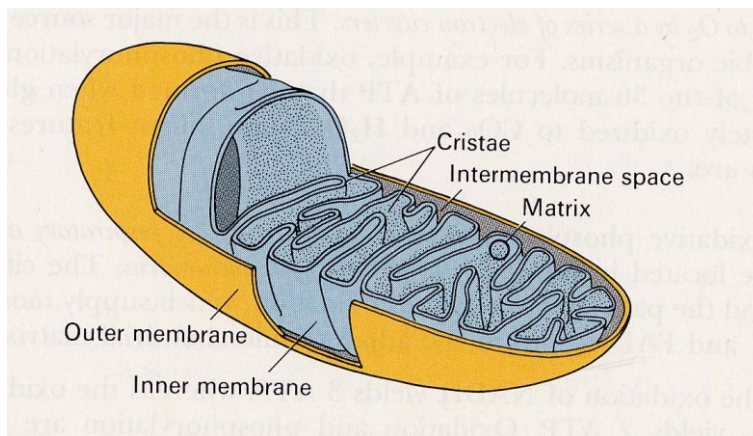

Mitochondria are the powerhouses of the cell, generating the bulk of the cellular ATP. They were first shown to contain the enzymes of the Krebs cycle in 1949. They have an outer membrane (which limits the size of the organelle) and an inner membrane (folds that project inward called **cristae**).

The reactions of oxidative phosphorylation take place in the inner membrane, in contrast to the Krebs Cycle reactions which occur in the **matrix**. Numerous folds within the cristae increase the surface area upon which oxidative phosphorylation can take place.

Within the mitochondria, the co-enzymes NADH and FADH₂ are re-oxidised by molecular oxygen in the reactions:

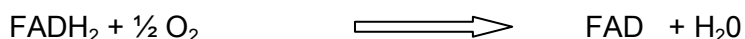
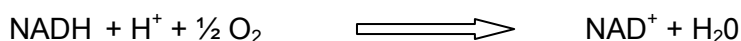

Each reaction has a ΔG of -223 and -170 kJ/mol respectively.

You may recall that ΔG for ATP hydrolysis is -31 kJ/mol (Lecture 2). Thus, the energy released from the re-oxidation of NADH and FADH₂ is enough to generate several phosphoanhydride bonds. Part of this energy is recovered by the components of the **electron transport chain** and used to synthesise ATP.

Chemiosmotic Hypothesis of Oxidative Phosphorylation

Oxidative Phosphorylation proceeds in two steps:

- 1) The translocation or movement of protons from within the matrix of the mitochondria. This is controlled by the *electron transport* or respiratory chain.
- 2) The pumped protons are allowed back into the mitochondria through a specific channel, which is coupled to an enzyme which can synthesise ATP (**ATP synthase**). See Alberts, Figure 14-2, page 455 for a nice analogy of the theory with a battery operated pump.

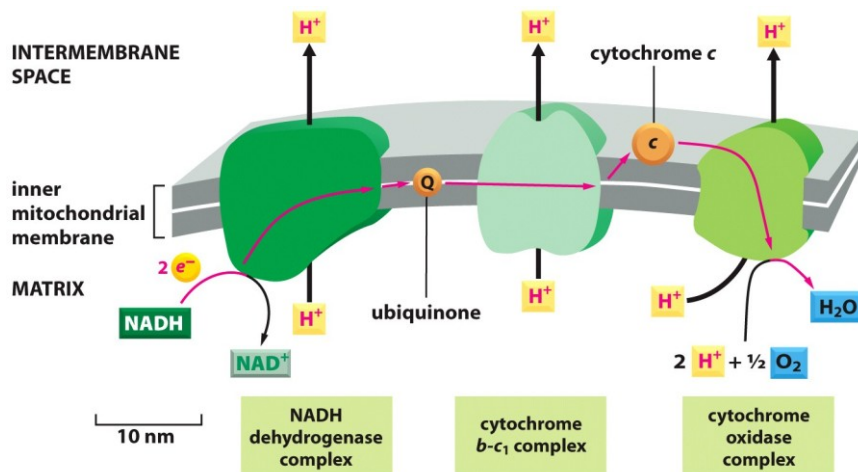

The Electron Transport Chain (Alberts p 461)

Enzymes

NADH Dehydrogenase complex, Cytochrome b-c1 complex, Cytochrome oxidase complex

Carriers

Ubiquinone (a.k.a. co-enzyme Q), Cytochrome C.

These proteins accept

electrons and in doing so, a proton (H^+) from the aqueous solution.

As electrons pass through each of the complexes, a proton is passed or 'pumped' to the intermembrane space.

Redox (Reduction-Oxidation) reactions are defined as electron transfer reactions involving a *reduced* substrate (which donates electrons and therefore becomes oxidised) and an *oxidised* substrate (or oxidant) which accepts electrons and becomes reduced in the process.

A substrate that can exist in both oxidised and reduced forms is known as a **redox couple**. e.g. $NAD^+/NADH$; $FAD/FADH_2$; Fe^{3+}/Fe^{2+} ; $1/2 O_2/H_2O$. The ability of a redox couple to accept or donate electrons can be determined experimentally and is known as the **reduction potential** or **redox potential**. Standard redox potentials (E°) can be measured experimentally.

A negative E° implies that the redox couple has a tendency to **donate** electrons and therefore has more reducing power than hydrogen. e.g. $NAD^+/NADH$ $E^{\circ} = -0.32$ V

Conversely, a positive E° implies that the redox couple has a tendency to **accept** electrons and therefore has more oxidising power than hydrogen.

e.g. Fe^{3+}/Fe^{2+} , $E^{\circ} = +0.77$ V; $1/2 O_2 + 2 H^+/H_2O$, $E^{\circ} = +0.82$ V.

As you might expect, the transfer of electrons from one complex to another is energetically favourable and as they progress along the chain, the electrons lose energy.

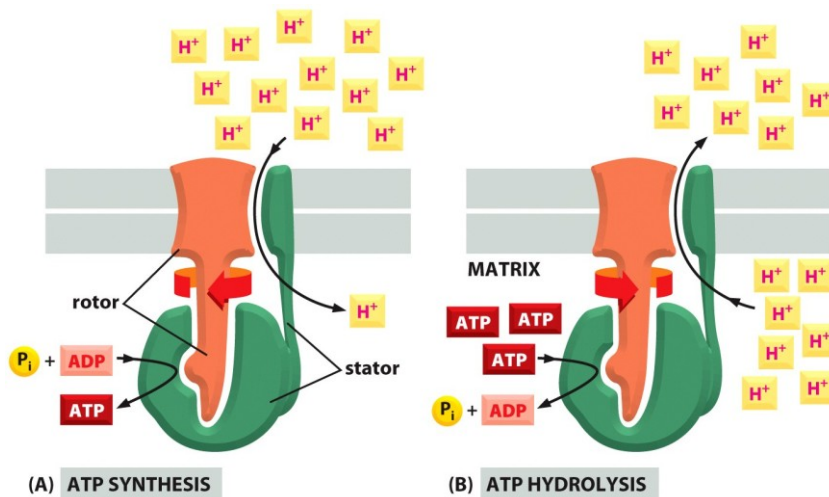

(A) ATP SYNTHESIS
formation of ATP (chemical energy).

(B) ATP HYDROLYSIS

ATP synthase is a multimeric enzyme consisting of a membrane bound part (F_0) and a F_1 part which projects into the matrix space. Rotation of the enzyme drives transitions states, with altering affinities for ATP and ADP. As a consequence, **conformational energy** flows from the catalytic subunit into the bound ADP and P_i to promote the

The Direction of Proton Flow dictates ATP Synthesis v ATP Hydrolysis

Alberts, page 463.

i.e. depending on the direction of the flow of protons through the ATP synthase, the complex can either generate ATP or consume it.

Nice animations of ATP synthase can be found online at http://nature.berkeley.edu/~hongwang/Project/ATP_synthase/

Succinate dehydrogenase is an integral membrane protein that is firmly attached to the inner surface of the inner mitochondrial membrane. There, it can communicate directly with ubiquinone. *As such one less proton is pumped to the intermembrane space, c.f. NADH and as a consequence, less ATP is produced.* The same is true for electrons donated by other $FADH_2$ species, e.g. glycerol phosphate shuttle, β -oxidation of fatty acids.

ATP consumption is a matter of life or death

The average human body synthesises around 70kg of ATP per day. Each of these ATP molecules has a lifespan of between 1 and 5 minutes. Consequently, any interruption to the process of oxidative phosphorylation and therefore to ATP synthesis, means that a cell rapidly becomes depleted of ATP and is likely to die.

Cyanide (CN^-) and **azide (N_3^-)** bind with high affinity to the ferric (Fe^{3+}) form of the haem group in the cytochrome oxidase complex.

This blocks the flow of electrons through the respiratory chain and consequently, the production of ATP. Similarly, carbon monoxide (CO) binds to the ferrous (Fe^{2+}) form of the haem group, also blocking the flow of electrons.

Malonate closely resembles succinate and acts as a competitive inhibitor of succinate dehydrogenase. This is the one Krebs Cycle enzyme that resides in the inner mitochondrial membrane and passes its electrons directly to ubiquinone via FAD. Malonate effectively slows down the flow of electrons from succinate to ubiquinone by inhibiting the oxidation of succinate to fumarate.

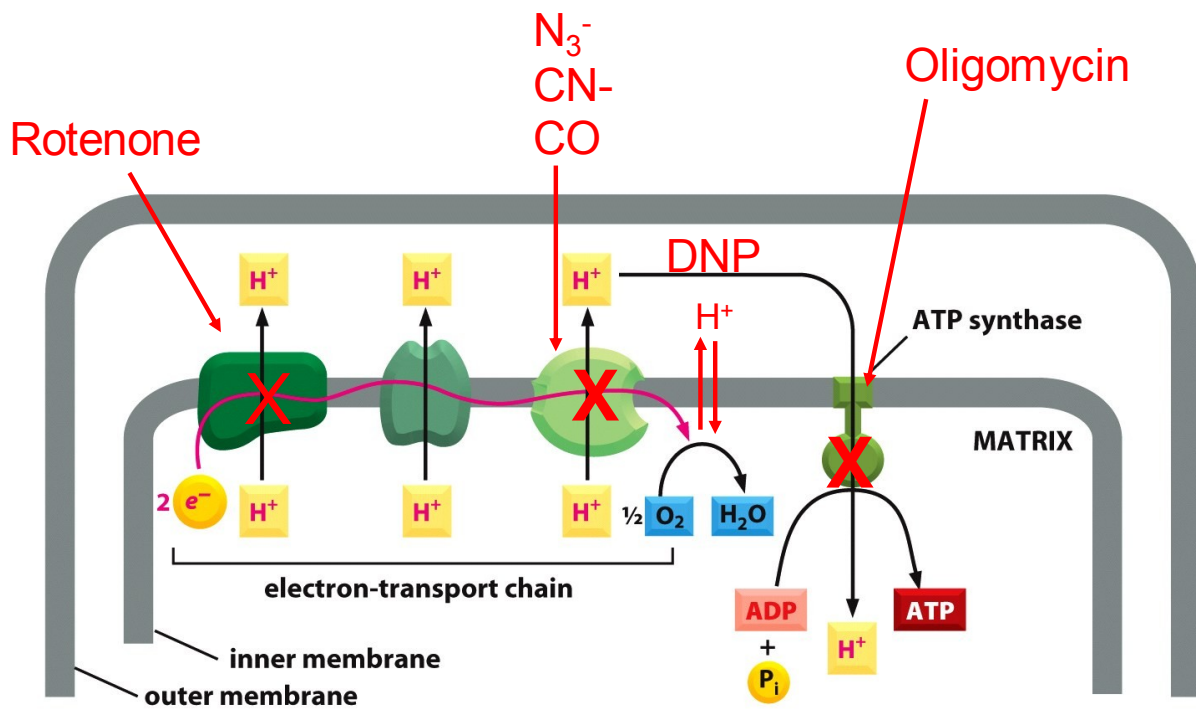

Oligomycin is an antibiotic produced by *Streptomyces* that inhibits oxidative phosphorylation by binding within the 'stalk' of ATP synthase. In doing so, it blocks the flow of protons through the enzyme. As a result, ATP synthesis is inhibited and a backlog of protons will build up in the intermembrane space. This in turn, will eventually inhibit the flow of electrons through the electron transport chain as the $[H^+]$ outside the mitochondrion will build up to saturation point at which no more protons can be pumped out against this proton gradient.

Dinitrophenol (DNP) can transport protons across the mitochondrial membrane, thereby uncoupling oxidative phosphorylation from ATP production and markedly increasing the metabolic rate and body temperature. It was used as a treatment for obesity in the 1930's, but since the margin between the slimming dose and that required to poison or kill is slight its use was rapidly abandoned.

NUCLEIC ACIDS AND GENE EXPRESSION 4

Gene Organisation & Transcription Part 2 - mRNA Processing

Dr Laki Buluwela, l.buluwela@imperial.ac.uk

Learning Objectives

- Describe, with the aid of diagrams, the events that take place in pre-mRNA processing
- Define what is meant by a “splice donor site”
- Define what is meant by a “splice acceptor site”
- Describe the “lariat” intermediate in mRNA splicing
- Define the function of the “Spliceosome”
- Describe the addition of a “cap” and “poly A tail” to pre-messenger (hn-) RNA.
- With examples, describe how mutations in splice sites feature in human disease.

The Anatomy of a Gene

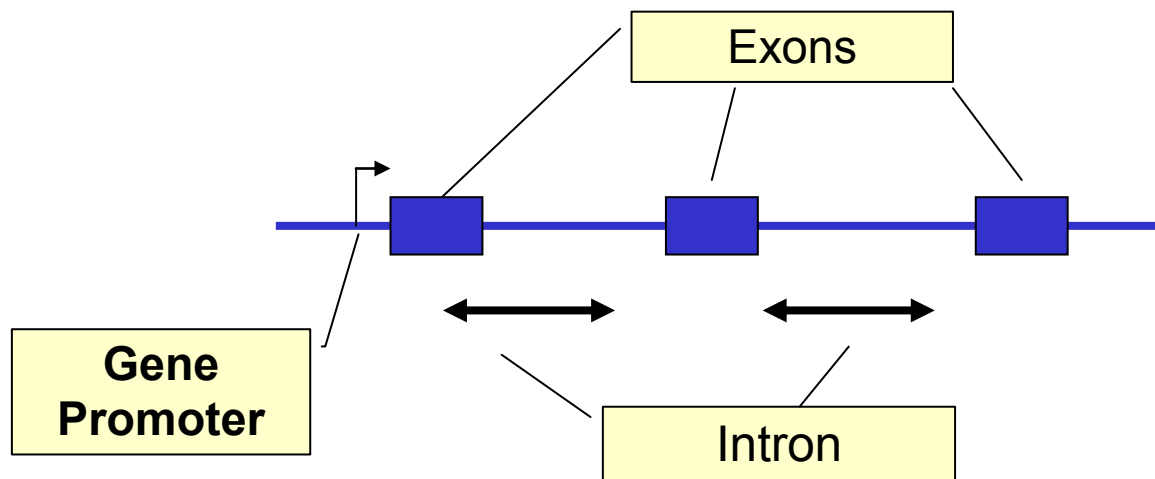

- The promoter lies at the start (5' end) of the gene
- The sequence information contained in the final mRNA is encoded “discontinuously” in the DNA of the gene
- Segments of the gene which contain sequences that form part of the final RNA are called “**exons**”
- “**Introns**” are sequences in the gene which are transcribed but are edited out of the final mRNA

The sequence of events in mRNA splicing

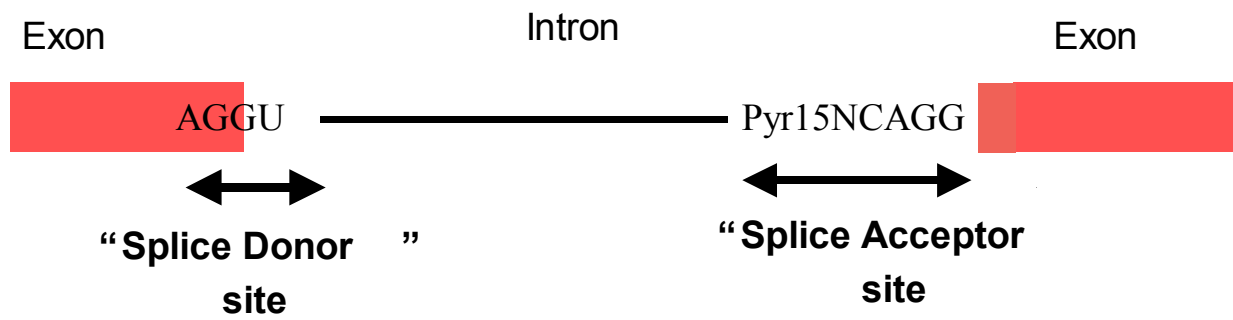

Pyr = Pyrimidine (C or U)
 N = any base

Introns start with the sequence “GU” and end with the sequence “AG”

The sequence of events in mRNA splicing

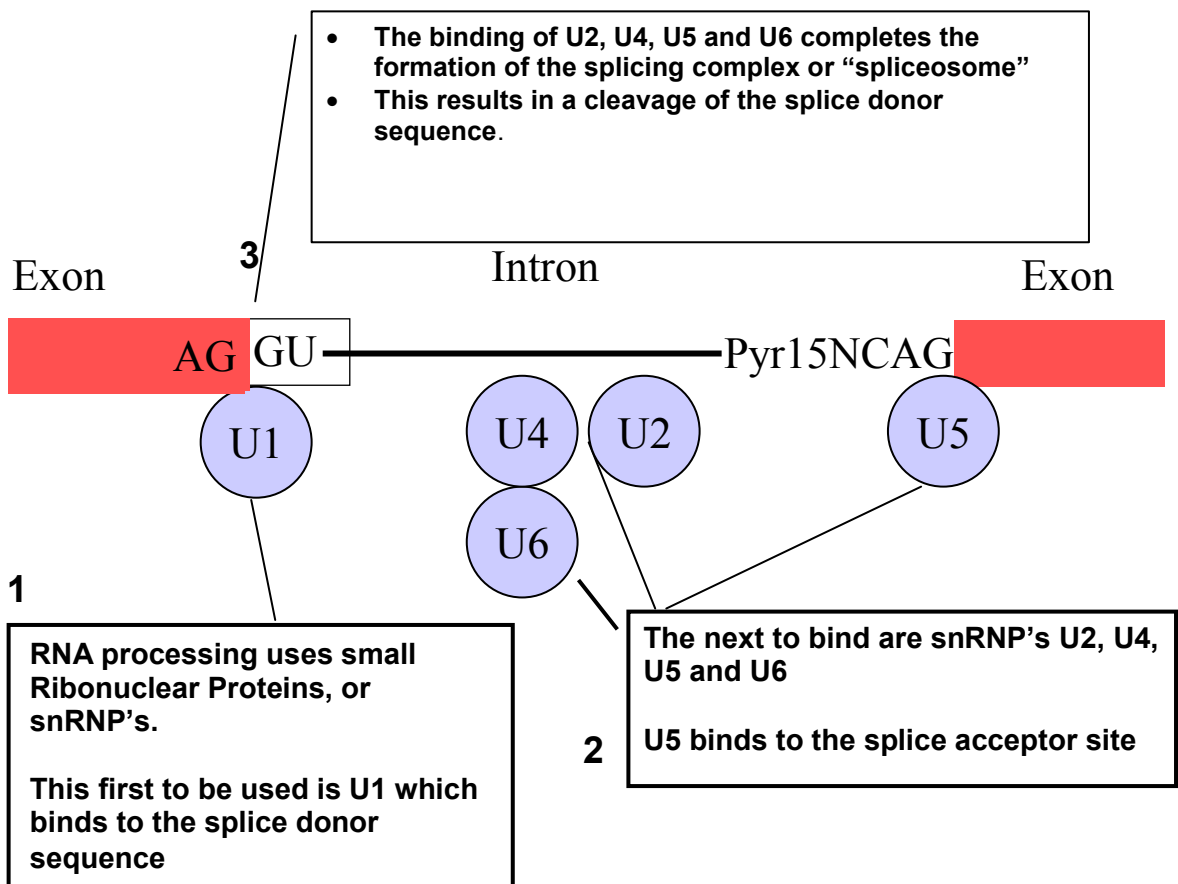



The intron removed as a "lariat" structure. The "branch" results from a phosphodiester bond between the 5' phosphate on the "G" at the start of the cleaved intron and the 2' OH of the branchpoint "A".

METABOLISM 6

Lipid metabolism

James Pease (Leukocyte Biology, NHLI)

Learning Objectives

- Appreciate the chemical composition of unsaturated and saturated fatty acids.
- Describe the reactions by which the fatty acid palmitate is metabolised to give acetyl-CoA.
- Give an overview of the reactions by which fatty acids are synthesized from acetyl-CoA.
- Compare and contrast the pathways for synthesis and metabolism of fatty acids with respect to the substrates and products, coenzymes used, carrier molecules and their cellular location.
- Give two examples of inborn errors of lipid metabolism with reference to the molecular defects underlying pathology.

Fatty acids (FA) are composed of a hydrophobic carbon chain and a hydrophilic head group and can be *saturated* with hydrogens (saturated fatty acids) or *unsaturated* (with one or more double bonds). They are typically stored as triacylglycerol (TAG) species. Double bonds introduce kinks into the carbon chains of these molecules and means that they pack less tightly together, and are generally liquid at room temperature. In contrast, saturated fatty acids pack tightly together and are generally solid at room temperature. In mammals, fatty acids are stored as triglycerides in the cytoplasm of specialised cells known as *adipocytes*.

Fats are derived from three primary sources, namely the diet, *de novo* synthesis by the liver and release from storage depots in adipocytes. Lipid digestion by the action of lingual gastric and pancreatic lipase results in the formation of Monoacylglycerol (MAG), diacylglycerol (DAG) and free FAs. During digestion, bile salts are released from the gall bladder and help to solubilize fatty acid molecules, forming *micelles* which include other molecules such as cholesterol, lysophosphatidic and fat-soluble vitamins e.g. A, D, E and K. Fatty acids from the micelles are absorbed by enterocytes lining the brush border of the small intestine and TAGs are resynthesized under the control of several enzymes prior to incorporation into chylomicrons (CM) and transportation (covered in lecture 7). If bile salts are lacking (e.g. obstruction of the bile duct by a gallstone) then fat may pass through the gut undigested resulting in *steatorrhea* (fatty stool). Steatorrhea is also a major side effect of Orlistat/lipstatin usage, which prescribed as an obesity treatment and is an inhibitor of gastric and pancreatic lipases.

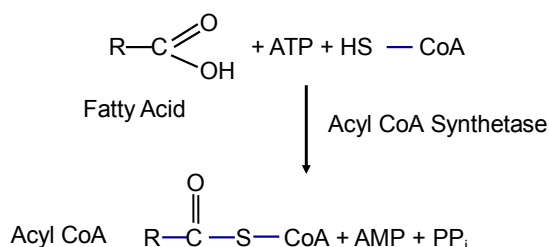

i.e. **ATP** \longrightarrow **AMP**, 2 high energy bonds are used.

More than half of the body's energy needs including the liver, but not the brain, comes from fatty acid oxidation (**β -oxidation**) in the mitochondria which is enhanced during fasting over long periods of time. β -oxidation occurs in several stages and results in the generation of acetyl coA. Fatty acids are firstly converted into an acyl CoA species via the enzyme *Acyl CoA synthetase* which requires ATP hydrolysis (left).

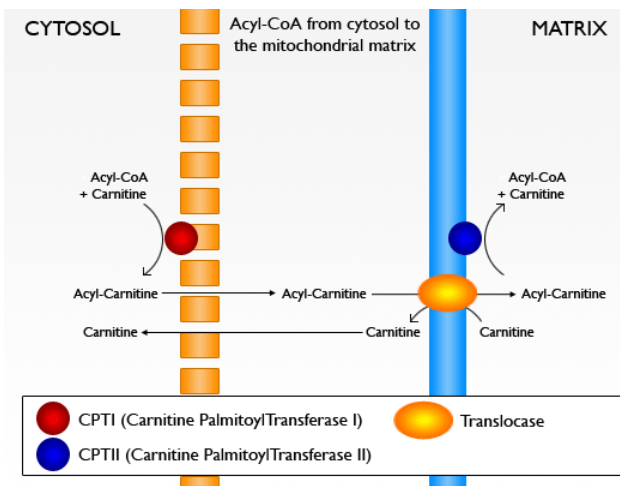

Carnitine Shuttle

The previous reaction occurs in the outer mitochondrial membrane, whereas the subsequent steps of β -oxidation occur in the mitochondrial matrix. To transport the acyl CoA species into the matrix it is coupled to the molecule carnitine to form acyl carnitine. Carnitine and Acyl carnitine are the shuttled to and from the mitochondrial matrix by an enzyme known as a translocase.

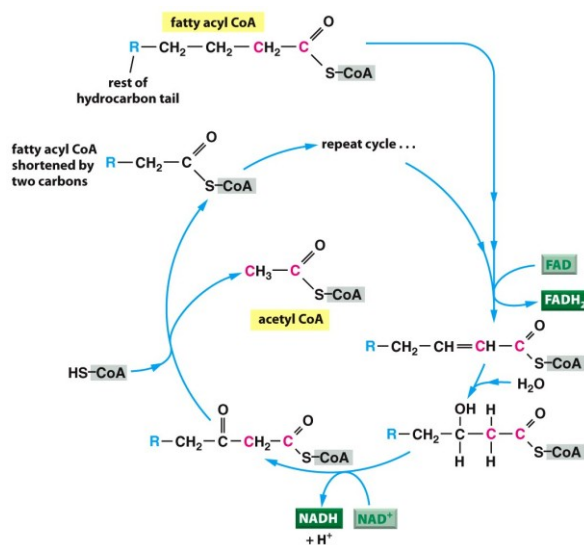

β -oxidation cycle. The acyl coA undergoes a sequence of oxidation, hydration, oxidation and thiolysis reactions (collectively called β -oxidation). This results in the production of one molecule of acetyl CoA and an acyl CoA species which is 2 carbons shorter than the original. On the final cycle (4-carbon fatty acyl CoA intermediate), two acetyl CoA molecules are formed.

If we consider the β -oxidation of the 16C fatty acid palmitate, then from 7 cycles of β -oxidation reactions, 8 molecules of acetyl CoA. During each cycle one molecule each of FADH_2 and NADH are produced.

The overall reaction of β -oxidation of palmitoyl CoA is as follows:

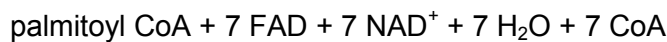

From the β -oxidation of one molecule of palmitate, 129 ATP molecules can theoretically be generated, which compares favourably with that of glucose (38 ATP molecules).

Fatty acid biosynthesis involves just two enzymes: *Acetyl CoA Carboxylase* and *Fatty acid synthase* (FAS) and has obvious similarities to β -oxidation. Initially, Acetyl CoA Carboxylase carboxylates Acetyl CoA to form the 3C species malonyl CoA which FAS takes and condenses with another Acetyl CoA molecule to form a 4C-species known as β -ketoacyl-ACP. **ACP** is an acronym for *acyl carrier protein* which provides a swinging arm mechanism to move the fatty acid chain from one domain to another, analogous to that of the pyruvate dehydrogenase complex (lecture 4). Following each round of elongation, the newly synthesized fatty acid undergoes reduction and dehydration by the sequential action of a ketoreductase (KR), dehydratase (DH), and enol reductase (ER). After several cycles, the fully grown fatty acid is hydrolyzed from the ACP. For biosynthesis of the 16C fatty acid palmitate, the overall reaction is as follows:

Acetyl CoA (C2) + 7 Malonyl CoA (C3) + 14 NADPH + 14 H⁺

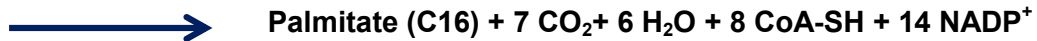

Main distinctions between Fatty acid biosynthesis and β -oxidation are the source of reducing power and the carrier proteins involved (NADPH/NAD⁺) and the carrier proteins involved (ACP/ Co-enzyme A).

To generate to fatty acids longer than 16 carbons, **Elongation** of the acyl group occurs separately from palmitate synthesis in the mitochondria and endoplasmic reticulum (ER).

Desaturation of fatty acids requires the action of *fatty acyl-CoA desaturases*

The enzyme that creates oleic acid and palmitoleic acid from stearate and palmitate, respectively, is called a Δ -9 desaturase, as it generates a double bond nine carbons from the terminal carboxyl group.

Disorders of Fatty Acid Metabolism

A family of 5 different Acyl-CoA-dehydrogenases catalyze the initial step in each cycle of fatty acid β -oxidation within the mitochondria matrix:

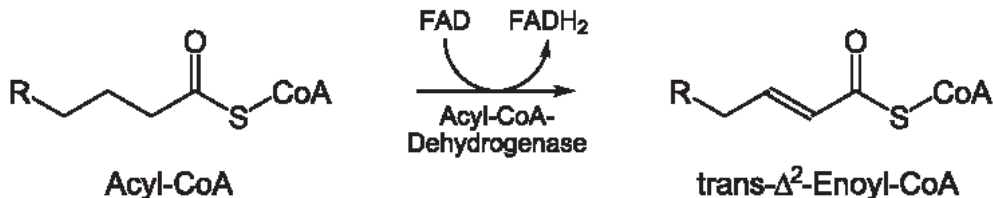

Each Acyl-CoA-dehydrogenase can bind a fatty acid chain of varying lengths:

- 3-hydroxyacyl-coenzyme A dehydrogenase
- Short-chain acyl-coenzyme A dehydrogenase
- Medium-chain acyl-coenzyme A dehydrogenase
- Long-chain 3-hydroxyacyl-coenzyme A dehydrogenase
- Very long-chain acyl-coenzyme A dehydrogenase

Medium-chain acyl-coenzyme A dehydrogenase deficiency (MCADD)

This is an autosomal recessive disorder, predominantly occurring in Caucasians and occurring in around 1 in 10,000 live births in the UK per year. If undiagnosed, it can be fatal and is thought to account for 1 in 100 deaths from Sudden Infant Death Syndrome (SIDS).

If diagnosed, patients should be instructed never to go without food for longer than 10–12 hours (a typical overnight fast) and to adhere to a high carbohydrate diet. Patients with an additional illness resulting in appetite loss or severe vomiting may need *i.v.* glucose to make sure that the body is not dependent on fatty acids for energy.

Primary Carnitine deficiency

This is an autosomal recessive disorder resulting from mutations in a gene known as SLC22A5 which encodes a carnitine transporter needed for the uptake of carnitine which is required for the β -oxidation of fatty acids. Symptoms appear during infancy or early childhood and include encephalopathies, cardiomyopathies, muscle weakness; and hypoglycaemia. It can be successfully treated by prescribing carnitine supplements e.g. Carnitor® /Levocarnitine.

METABOLISM 7

Cholesterol

James Pease (Leukocyte Biology, NHLI)

Learning Objectives

- Outline the synthesis of cholesterol from acetyl CoA.
- Outline the synthesis of bile acids and steroid hormones from cholesterol.
- Describe the mechanism of transport of cholesterol around the body and its uptake into cells.
- Draw a diagram of low density lipoprotein (LDL) particle and its receptor (LDLR).
- Explain how mutations of the LDLR give rise to familial hypercholesterolaemia
- Give examples of pharmacological agents that may be used to control cholesterol metabolism.

Cholesterol Synthesis

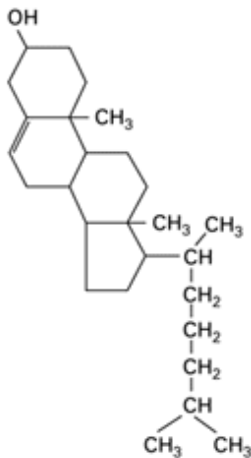

More than 90% of the body's **cholesterol** (left) is found in cell membranes where it can increase or decrease membrane stiffness, depending on temperature and nature of membrane (see Cells Lecture 1). Although some is taken up in the diet, the majority is synthesized by the liver from acetyl-CoA. The pathway of cholesterol synthesis can be split into three main parts:

1. Synthesis of mevalonate, a reduced C₆ species from 3 Acetyl-CoA units.
2. Activation of mevalonate to isopentenyl-PP (isoprene unit), a C₅ precursor which is elongated to a squalene, a C₃₀ intermediate species.
3. Cyclisation and demethylation of squalene by monooxygenases to give cholesterol.

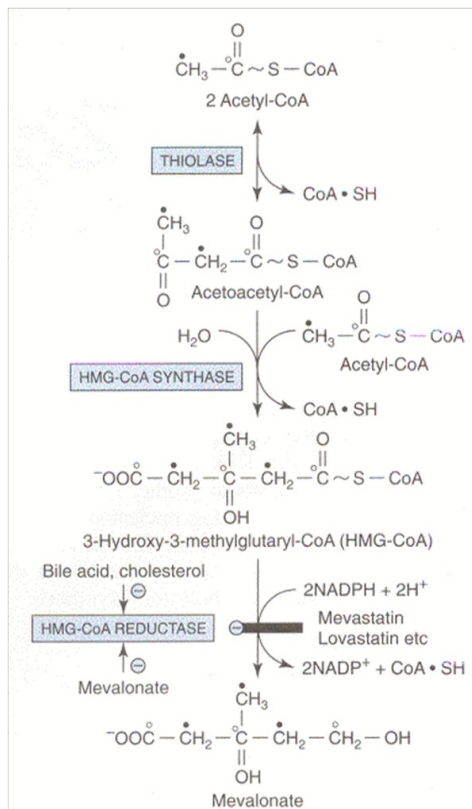

1. In the first instance (left), 3 x Acetyl-CoA molecules are sequentially combined to generate 3-Hydroxy-3-methylglutaryl CoA (HMG-CoA) catalysed by *HMG-CoA-synthase*. HMG-CoA is then reduced by the enzyme *HMG-CoA reductase* to generate mevalonate. HMG-CoA reductase is under negative feedback control by the end product cholesterol, the intermediate mevalonate and also the action of bile salts. HMG-CoA reductase is also a target of *statins*.

2. Mevalonate undergoes sequential phosphorylation at the hydroxyl groups at position 3 and 5 to form Mevalonate 3-phospho-5-pyrophosphate. This is decarboxylated to form the C₅ species isopentenyl pyrophosphate (IPP). In an isomerization reaction 3,3-dimethyl-PP_i is produced which condenses with one unit of isopentenyl-PP_i to form the C₁₀ compound geranyl-PP_i. A third isopentenyl-PP_i molecule is added to form the C₁₅ intermediate farnesyl-PP_i, two of which condense to form squalene plus 2 molecules of pyrophosphate. This reaction is driven by the reducing power of NADPH.

3. Squalene is subsequently cyclised to cholesterol, via the intermediate lanosterol.

Cholesterol is a versatile molecule

Cholesterol is the basis of all 5 classes of steroid hormones (**Progestins, Glucocorticoids, Mineralocorticoids, Androgens and Estrogens**) via the precursor **pregnenolone** which is generated from cholesterol by the action of the enzyme desmolase. Cholesterol is also a major source of vitamin D3 which is found at low levels in most foods and a deficiency of which leads to *rickets*. Exposure of **7-Dehydrocholesterol** in the epidermal layers of skin to UV radiation results in its metabolism to calcitriol, the active form of Vitamin D3 which plays a key role in Ca^{2+} metabolism. **Bile salts** are the major breakdown products of cholesterol and account for about half of the 800 mg of cholesterol made each day by the liver. Cholesterol also plays major roles in **cell signaling**. It is a key component of **lipid rafts**, fluctuating assemblies of cholesterol and sphingolipids within a plasma membrane where they organize signaling molecules into discreet domains. Cholesterol also modifies the **hedgehog** signaling protein (N-Hh) limiting its diffusion within tissues during embryogenesis.

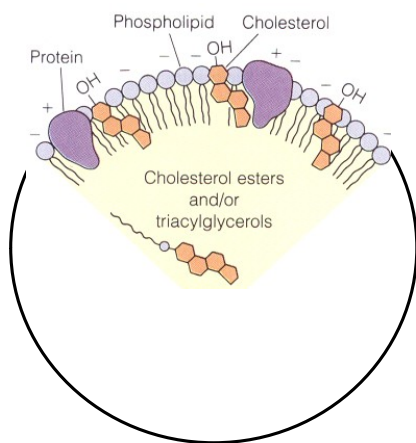

Lipid transport

The insolubility of lipids in aqueous solutions poses transportation problems for the body which is solved by packaging them within lipoproteins (left), composed of a phospholipid monolayer containing cholesterol and proteins known as apoproteins e.g. Apo A-I, Apo B-100 and Apo E. Packed within the core of the lipoprotein are a mixture of cholesterol esters and triacylglycerols. **Cholesterol esters** are synthesized in the plasma from cholesterol and the acyl chain of phosphatidylcholine (lecithin) via a reaction catalyzed by *lecithin:cholesterol acyltransferase* (LCAT).

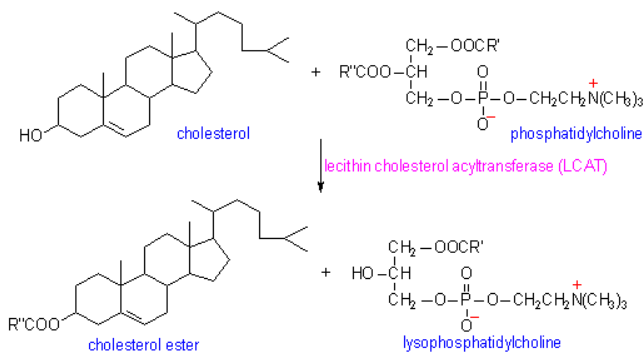

This cholesterol esters more hydrophobic than cholesterol and allows them to pack more tightly within the lipoprotein core. Alternatively, the enzyme *Acyl CoA-acyltransferase* (ACAT) can generate mechanism cholesterol esters from a long chain fatty acyl CoA species. ACAT is an intracellular enzyme and acts on cholesterol taken up into cells by endocytosis.

Lipoproteins are categorized according to their density and come in five forms:

Chylomicrons (CM), Very low density lipoproteins (VLDL), Intermediate density lipoproteins (IDL), Low density lipoproteins (LDL) and High density lipoproteins (HDL). VLDL are the precursors of IDLs and IDLs are the precursors of LDL. Each type of lipoprotein has a varying apoprotein component which allows them to be recognized by different cell types. **LDL** and **HDL** are principle lipoproteins and play key roles in cholesterol transport.

Chylomicrons (CMs) are transported via the lymphatics into the bloodstream and broken down by the enzyme **Lipoprotein lipase** located on the capillary endothelial cells lining a variety of tissues including adipose, heart and skeletal muscle. The triacylglycerols within the chylomicrons are hydrolysed to glycerol and fatty acids, the latter undergoing β -oxidation. Glycerol is returned to the liver for use in gluconeogenesis (lecture 9).

HDLs are often referred to as "good cholesterol" as they function to take cholesterol from peripheral tissues back to the liver for use or disposal (reverse transport). They help to lower total serum cholesterol. **LDLs** are often referred to as "bad cholesterol" as prolonged elevation of LDL levels leads to atherosclerosis (hardening of the arteries). LDLs transport cholesterol synthesized in the liver to peripheral tissues with more than 40% of their weight made up of cholesterol esters.

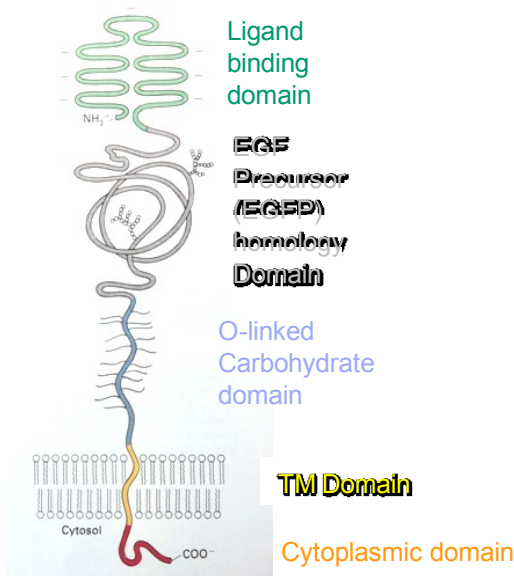

LDL are taken up by specific cell-surface receptor known as **LDL receptors** or LDLR (left) in a process known as receptor mediated endocytosis (lecture 8). Mutations within the LDLR gene can result in the disease known as **Familial hypercholesterolaemia (FH)** which is inherited as a monogenic dominant trait.

Individuals who carry a single copy of a mutant gene (heterozygotes) have cholesterol levels approximately 2-3 times higher than in normal people and are susceptible to atherosclerosis in middle age. Homozygotes carrying two copies of a mutant gene are severely affected with serum cholesterol levels five times higher than normal and severe atherosclerosis and coronary infarction may be observed in adolescence.

Over 1000 different LDL mutations have been identified which lead to FH, which fall into five major classes:

Class	Location of Mutation	Result
I:	Mutation in LDLR promoter/frame shift/deletion	LDLR is not synthesized.
II	Throughout the coding region	LDLR is not properly transported from the ER to Golgi leading to low cell surface expression.
III	Mutation in region encoding N-terminus	LDLR does not bind LDL effectively.
IV	Mutation in cytoplasmic domain	LDLR:LDL complex does not cluster in clathrin-coated pits for receptor-mediated endocytosis.
V	Mutation in EGFP domain	LDL is not released from the receptor in the endosome and LDLR is not recycled back to the cell surface.

Control of hypercholesterolaemia

HMG-CoA-Reductase inhibitors a.k.a. Statins e.g., Lipitor (Pfizer), Crestor (AZ).

These act at an early stage during cholesterol biosynthesis, inhibiting the production of mevalonate and therefore cholesterol.

Resins or sequestrants e.g. cholestyramine (brand names: Questran, Prevalite).

These bind or sequester bile acid-cholesterol complexes preventing their reabsorption by the intestine. They can decrease LDL levels by 15-30%.

GENETICS 1

Mrs Jones' first consultation

Dr Andrew Walley

Congenital abnormalities:

1. Deformation – distortion of a structure by mechanical force, e.g. club foot
2. Dysplasia – abnormal organization of tissue e.g. thanatophoric dysplasia
3. Malformation – primary structural defect, e.g. cleft lip
4. Disruption – extrinsic factor affecting normal development, e.g. digital amputation
5. Sequence – multiple abnormalities initiated by primary factor, e.g. Potter's sequence
6. Syndrome – consistent pattern of abnormalities, e.g. Down's syndrome
7. Association (as a medical term) – non-random occurrence of clinical features not explained by sequence or syndrome, e.g. VATER syndrome
8. Dysmorphism – an unusual or abnormal physical feature (sometimes as part of a genetic syndrome), e.g. hypertelorism

Meiosis and chromosomal segregation

There is an introduction to meiosis here: <http://meiosistutorial.net/>

Here is a short animation of chromosomal non-disjunction in meiosis 1 (think about how it would be different if the non-disjunction happened in meiosis 2):

http://www.biostudio.com/d_%20Meiotic%20Nondisjunction%20Meiosis%20I.htm

Here is an exploration of how errors in chromosome segregation can lead to Down's syndrome:

http://auth.mhhe.com/biosci/genbio/biolink/j_explorations/ch10expl.htm

Aneuploidies

Trisomy 21 (Down's syndrome)

Trisomy 18 (Edwards' syndrome)

Trisomy 13 (Patau syndrome)

Monosomy X (Turner's syndrome)

XXY (Klinefelter's Syndrome)

XYY and XXX

“Genomic disorders” or microdeletion/microduplication syndromes

di George syndrome

Cri du chat syndrome

Williams syndrome

NUCLEIC ACIDS AND GENE EXPRESSION 5: Protein translation & post-translational modification

Professor Tony Magee, NHLI
t.magee@imperial.ac.uk

- There is a linear relationship between the information encoded within DNA (the genetic code) and the proteins that are synthesised using that information
- Three nucleotides encode one amino acid, hence the name “triplet code”; a group of three nucleotides is called a codon
- Protein synthesis always starts with Met =AUG and finishes with a stop codon =UAA, UAG or UGA
- transfer RNAs are the transporters of amino acids (bound to the 3' terminus) to the ribosome; they contain an anticodon loop that binds to the corresponding codon on the mRNA
- **Translation initiates with:**
 - Step 1: dissociation of ribosome subunits (40S + 60S)
 - Step 2: assembly of preinitiation complex containing Met-tRNA + Initiation Factors + 40S subunit
 - Step 3: binding of mRNA to preinitiation complex
 - Step 4: binding of 60S subunit
- **Translation elongation proceeds with:**
 - Step 1: binding of new tRNA to A site
 - Step 2: catalysis of peptide bond between two amino acids by peptidyl transferase
 - Step 3: translocation of tRNA to P site and dissociation of first tRNA
- **Translation termination occurs by:**
 - Step 1: recognition of stop codon
 - Step 2: release of peptide chain
 - Step 3: dissociation of release factors and ribosomes
- Antibiotics are natural products of bacteria or fungi that can selectively inhibit prokaryotic protein synthesis because the translational machinery is complex and easily disrupted
- Synthesis of proteins destined for the secretory pathway to the cell surface occurs on Rough Endoplasmic Reticulum (RER) in the following stages:
 - Step 1: recognition of hydrophobic N-terminal signal sequence by signal recognition particle (SRP)
 - Step 2: binding of SRP to a receptor at the RER surface
 - Step 3: translocation of the growing protein into the lumen of RER
 - Step 4: cleavage of signal sequence and protein foldingTransmembrane proteins have additional hydrophobic sequences that stick in the membrane of the RER
- Post-translational modification - after synthesis many proteins, e.g. insulin, are modified further before they are fully functional. Modifications include:
 - Proteolytic cleavage
 - Disulphide bond formation
 - Addition of carbohydrate (Glycosylation)
 - Addition of phosphate (Phosphorylation)
 - Addition of lipid groups (Acylation, Prenylation)

GENETICS 2

Mrs Jones (2) – risk of transmission of genetic disease

Dr Jess Buxton

DRAWING FAMILY TREES

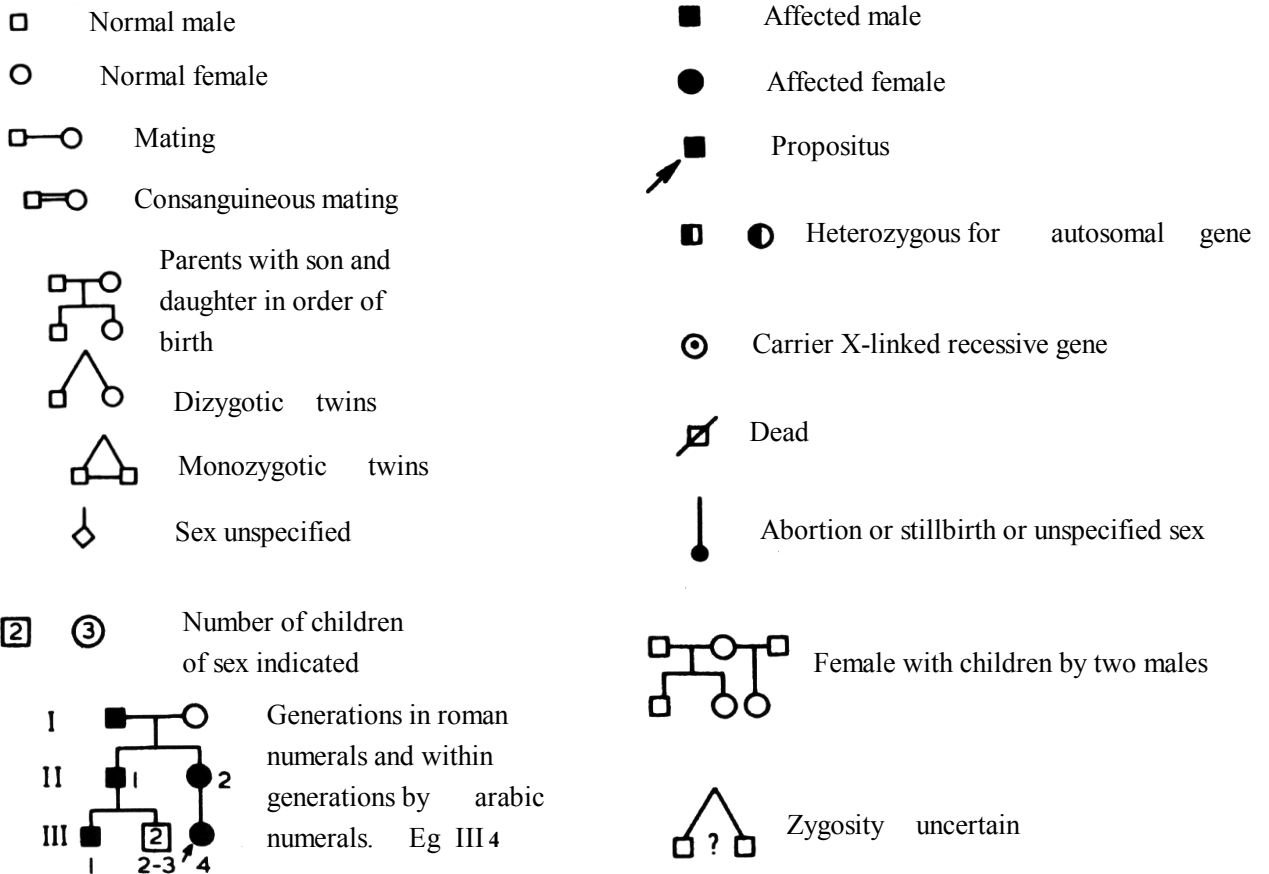

Alleles - the two copies of a gene in a diploid are called the two alleles.

Homozygous - both alleles of a particular gene the same.

Heterozygous - carrying different alleles of a particular gene.

Autosomal recessive inheritance

Aa heterozygotes are unaffected carriers
 aa homozygotes are affected

Pattern of inheritance in a family;

Affects males and females in equal proportions

1/4 children affected

Often does not affect previous and subsequent generations because these have non-symptomatic carriers

Consanguinity in the parents is frequent

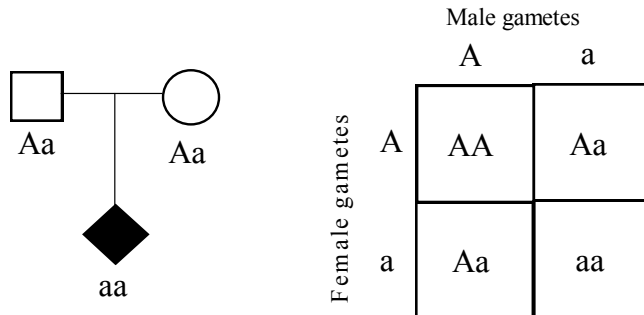

Autosomal dominant inheritance.

Aa heterozygous affected.

aa homozygous normal unaffected.

AA homozygous affected, very rare.

Pattern of inheritance in a family;

Affects males and females in equal proportion

Disease present in every generation (vertical transmission)

50% of offspring affected

Variable expressivity (variable severity)

Reduced penetrance (some carriers not affected)

New mutations frequently observed

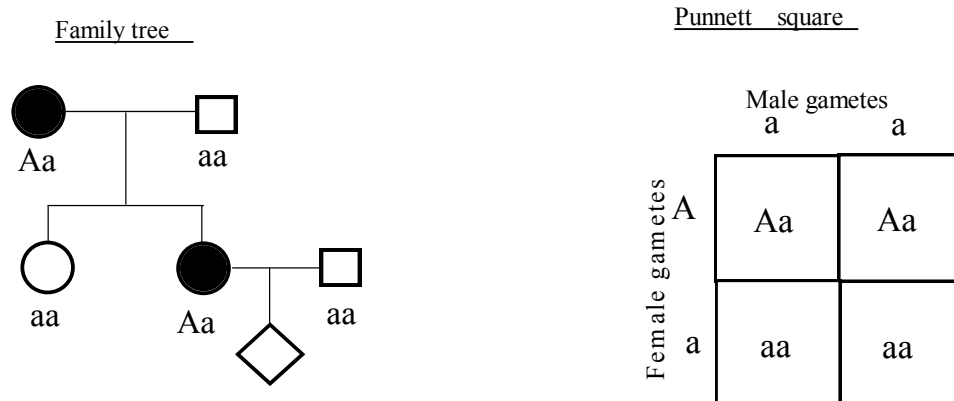

Co-dominant inheritance

Both alleles are expressed giving different phenotypes for AA, Aa and aa individuals.

The genetic basis of sex determination in humans

Females have two X chromosomes

Males have an X and a Y chromosome.

The X chromosome carries many genes.

The Y chromosome carries very few, apart from the male determining gene, SRY.

X-linked inheritance

$X_m X$ unaffected carrier female

$X_m Y$ affected male

Pattern of inheritance in a family;

Affects males almost exclusively.

Transmitted from carrier females to their sons.

An affected male can have affected grandsons through his daughters who are carriers.

No transmission from affected males to sons.

Variable expression in heterozygous females.

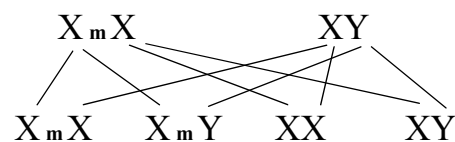
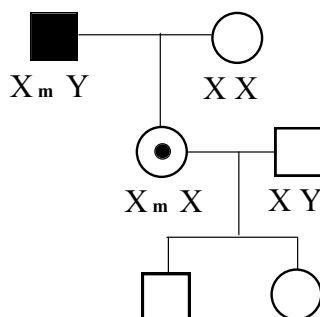

GENETICS 3

More stories from the genetics clinic

Dr Andrew Walley

Genetic imprinting refers to a situation where genes are expressed differently according to whether they are inherited on the chromosome that came from the mother or that from the father.

Prader-Willi syndrome is caused by loss of (or lack of gene expression from) the paternal copy of a region on the long arm of chromosome 15 (15q11-13)

<http://www.ncbi.nlm.nih.gov/omim/176270>

<http://www.ncbi.nlm.nih.gov/bookshelf/br.fcgi?book=gene&part=pws>

Angelman syndrome is caused by loss of the maternal copy of the same region

<http://www.ncbi.nlm.nih.gov/omim/105830>

<http://www.ncbi.nlm.nih.gov/bookshelf/br.fcgi?book=gene&part=angelman>

Can be caused by deletion, uniparental disomy or mutation in an imprinting region

Mitochondrial disorders are maternally inherited

<http://www.ncbi.nlm.nih.gov/bookshelf/br.fcgi?book=gene&part=mt-overview>

Heteroplasmy is the state where a mixture of normal and mutant mitochondria is present in the same cell. The proportions of normal and mutant mitochondria present affect disease expression.

NHS neonatal screening programmes use biochemical methods to test for genetic diseases from blood spots taken from heel prick of the neonate. Affected babies can receive early treatment and their families can be referred for genetic counseling.

<http://newbornbloodspot.screening.nhs.uk/professionals>

<http://newbornbloodspot.screening.nhs.uk/mcadd>

<http://newbornbloodspot.screening.nhs.uk/cf>

<http://newbornbloodspot.screening.nhs.uk/cms.php?folder=2464>

Population screening tests need to have both high **specificity** and high **sensitivity** to be useful.

TISSUES 1

Epithelial Cells

Dr Peter Clark

p.clark@imperial.ac.uk

The overall aim of this and the following lecture (Tissues 2) is to examine the specialisations of epithelial tissues by reviewing the sub-cellular organisation of cells and relating this to epithelial function. In addition, the tissue organisation of epithelia of different functions will be examined.

Multicellular organisms are made up of a wide variety of different cell types. This variety arises as a result of differentiation of precursor cells.

Main Cell Types

- **epithelial cells:** cells forming continuous layers, these layers line surfaces and separate tissue compartments
- **mesenchymal cells:** cells of the connective tissues, e.g. fibroblasts (many tissues), chondrocytes (cartilage), osteocytes (bone), muscle cells (skeletal, cardiac, smooth), the endothelial cells lining blood vessels.
- **haematopoietic cells:** blood cells and the cells of the bone marrow from which they are derived.
- **neural cells:** cells of the nervous system having two main types; neurones (carry electrical signals) and glial cells (support cells)

Tumours retain some characteristics of the cell type from which they originate

- epithelial cancers are **carcinomas**
- mesenchymal cancers are **sarcomas**
- haematopoietic cancers are **leukaemias** (from bone marrow cells) or **lymphomas** (from lymphocytes)
- neural cell cancers are **neuroblastomas** (from neurone precursors) or **gliomas** (from glial cells)

Tissue

- a group or groups of cells whose organisation and architecture are integral to its function
- tissues are made up of cells and extracellular matrix

Extracellular matrix

- material deposited by cells which forms the “insoluble” part of the extracellular environment
- generally composed of fibrillar (or reticular) proteins (e.g. collagens, elastin) embedded in a hydrated gel (proteoglycans or “ground substance”)
- may be poorly organised (e.g. loose connective tissue) or highly organised (e.g. tendon, bone, basal lamina)

Epithelial organisation

- epithelial cells make organised, stable cell-cell junctions to form continuous, cohesive layers
- epithelial layers line internal and external body surfaces and have a variety of functions, e.g. transport, absorption, secretion, protection

Cell-cell junctions

- continuous epithelial layers can form because cells form stable **cell-cell junctions** which give the epithelia mechanical integrity and act to seal the intercellular pathways.
- in many epithelia these are found at the apical region of cell-cell contact as a **junctional complex**.
- generally in 2 forms: **zonulae** (belts) or **maculae** (spots)

Cell-cell junctions in epithelia

- typically arranged as an apical junctional complex containing a **tight junction** nearest the apex, then an **adhesion belt**, then, scattered throughout the lateral membrane, **desmosomes** (spot adhering junctions)
- other important junctions are **gap junctions**, which act as regions of direct communication between adjacent cells

Tight junctions

(occluding junction)

- zonula occludens (belt junction)
- points on adjacent membranes form close contacts at apical lateral membranes
- form a network of contacts, the more elaborate the network, the tighter the seal
- act to seal paracellular pathways (i.e. between cells)
- segregates apical and basolateral membrane polarity

Adhesion belt

- zonula adherens (belt junction)
- usually formed just basal to the apical tight junction
- transmembrane adhesion molecule is **cadherin** (family of Ca^{2+} ion-dependent cell adhesion molecules)
- cadherins associate with the microfilament (actin) cytoskeleton
- this junction controls the organisation and stability of the other junctions (“master junction”)

Desmosome

(spot junction)

- macula adherens (spot desmosome)
- found at multiple spots between adjacent cell membranes
- transmembrane cell adhesion molecule is a cadherin-like molecule
- linked to the **intermediate filament** cytoskeleton
- provides good mechanical strength between cells

Gap junction

(communicating junction)

- macula communicans (spot junction)
- made up of clusters of pores formed from 6 identical subunits in the membrane - these pores are continuous with pores in adjacent cell membrane
- allows passage of ions and small molecules between cells
- pH, Ca^{2+} conc, voltage, and some signalling molecules can affect passage, i.e. can open and close pores thereby controlling intercellular communication

Synapse

(communicating junction)

- synapses mainly in neural tissue
- button-like junctions formed between neurones, or between neurones and target cells (e.g. muscle)
- information passed one-way via a chemical signalling system
- a variety of chemical signals and receptors are utilised at synapses

Cell-cell junctions

Cell-cell junctions are labile (capable of changing their assembly and organisation). The assembly and disassembly of junctions are controlled by a variety of factors in health and disease.

Cytoskeleton: the term used to describe a group of protein polymers which form structurally important cytoplasmic components.

Microtubules: polymers of α and β tubulin, ~20nm diam. Involved in cell shape, and act as "tracks" for the movement of other organelles and cytoplasmic components within the cell. Many accessory proteins involved in these functions. The major component of cilia and flagellae.

Intermediate filaments (IF): a group of polymers of filamentous proteins which form rope-like filaments. The type of IF a cell has is characteristic of cell type, e.g. Epithelia have cytokeratins; mesenchymal cells have vimentin; neurones have neurofilament protein. IFs give mechanical strength to cells. Desmosomes are connected by cytokeratins. Nuclear lamins are intermediate filaments found forming a network on the internal surface of the nuclear envelope, being involved in stabilising the envelope.

Microfilaments: polymers of actin associate with adhesion belts in epithelia and endothelia, and with other plasma membrane proteins. Involved in cell shape and cell movement (crawling of cells; cell contractility esp. muscle). Accessory proteins, e.g. myosin, act with actin to control actin organisation and cell movement.

Cytoskeleton organisation is highly labile, and is controlled by many factors. Re-organisation occurs during cell locomotion, cell division etc.

METABOLISM 8

Membrane Trafficking

Professor Tony Magee

INTRACELLULAR MEMBRANE ORGANISATION

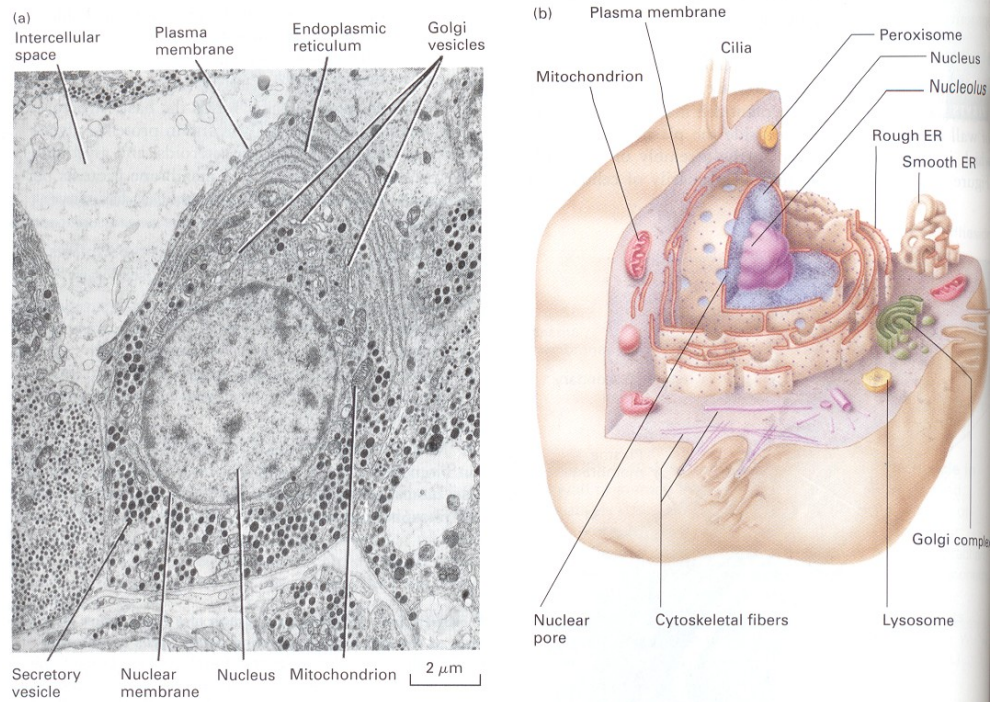

TYPES OF INTRACELLULAR TRANSPORT

1. Gated transport (e.g. nuclear import)
2. Trans-membrane transport (e.g. import of newly synthesized proteins into ER)
3. Vesicular transport (e.g. inter-organellar transport)

VESICULAR TRANSPORT COMPLEXITY

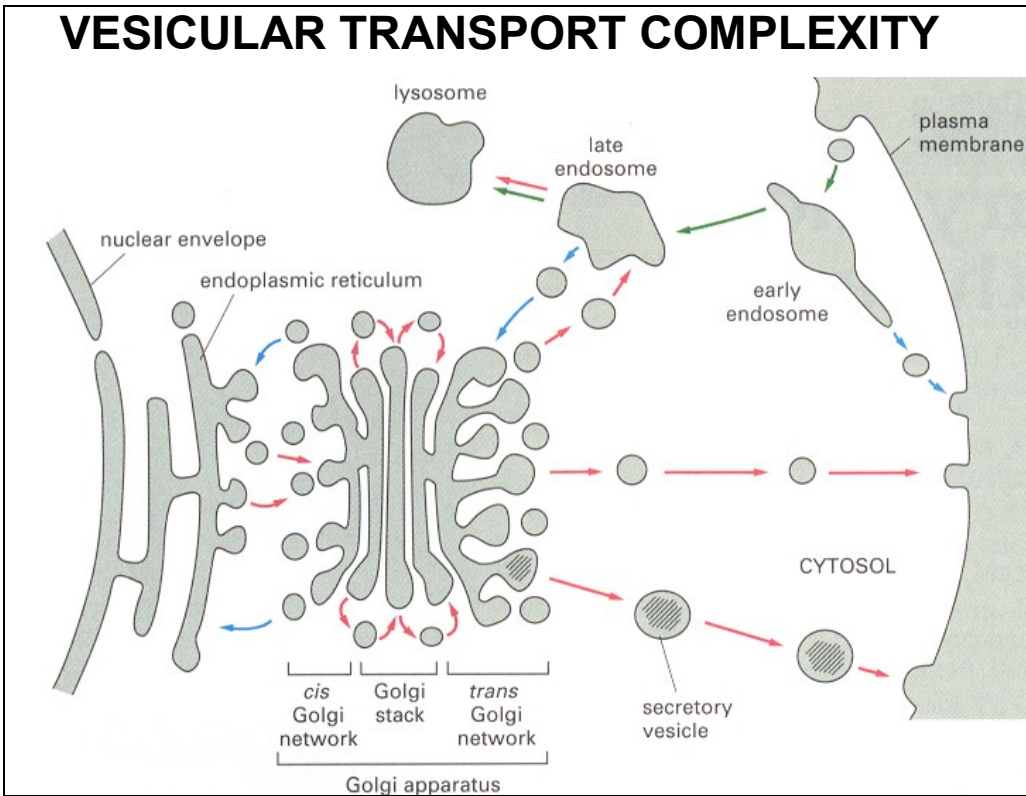

THE SECRETORY OR EXOCYTOTIC PATHWAY

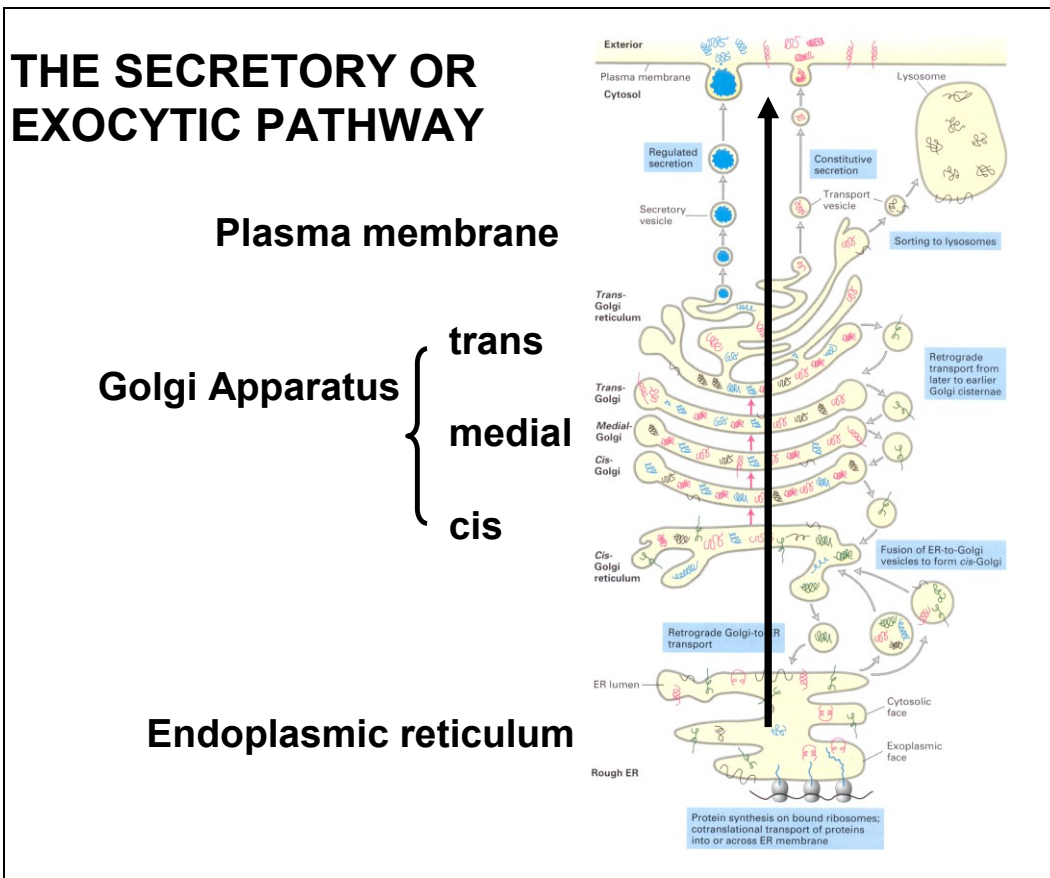

TRANSLOCATION OF NEWLY SYNTHESIZED PROTEINS INTO THE ER

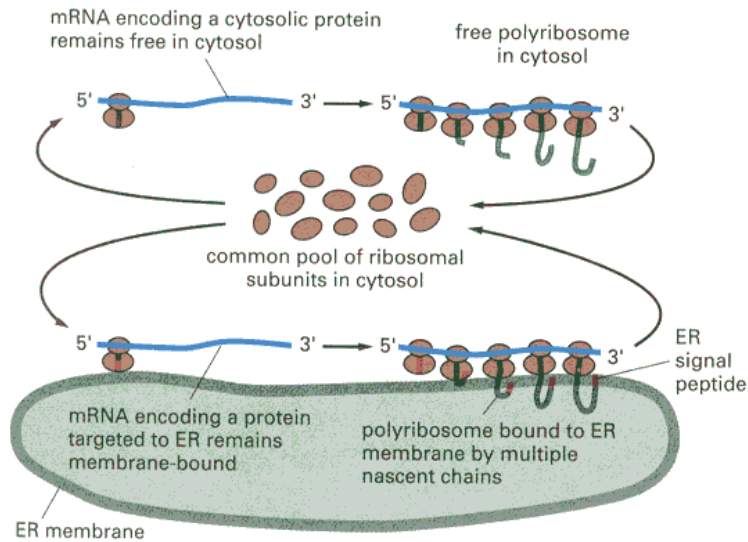

Free and membrane-bound ribosomes. A common pool of ribosomes is used to synthesize both the proteins that stay in the cytosol and those that are transported into the ER. It is the ER signal peptide on a newly formed polypeptide chain that directs the engaged ribosome to the ER membrane. The mRNA molecule may remain permanently bound to the ER as part of a polyribosome, while the ribosomes that move along it are recycled; at the end of each round of protein synthesis, the ribosomal subunits are released and rejoin the common pool in the cytosol.

ER: POST TRANSLATIONAL MODIFICATIONS AND QUALITY CONTROL

Modifications:

- Formation of disulfide bonds
- Folding
- Glycosylation
- Specific proteolytic cleavages
- Assembly of multimeric proteins

Unassembled or misfolded proteins are retained in the ER and exported back in the cytosol where they are degraded

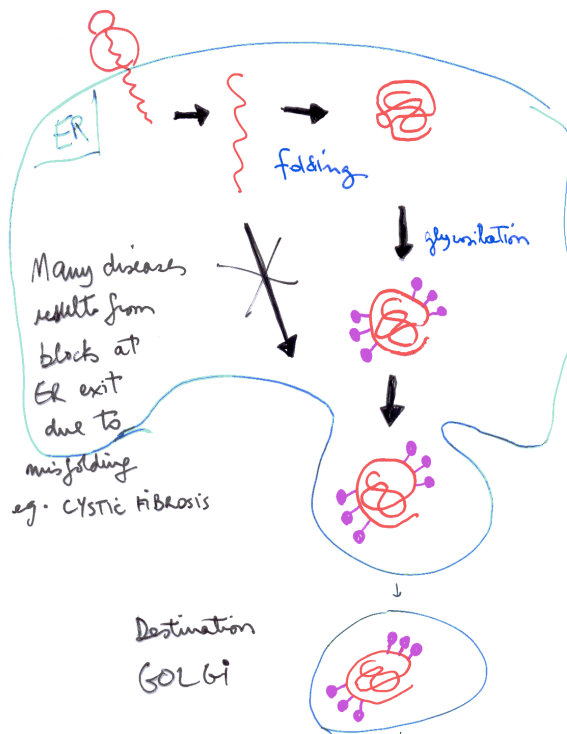

RETRIEVAL OF ER RESIDENT PROTEINS

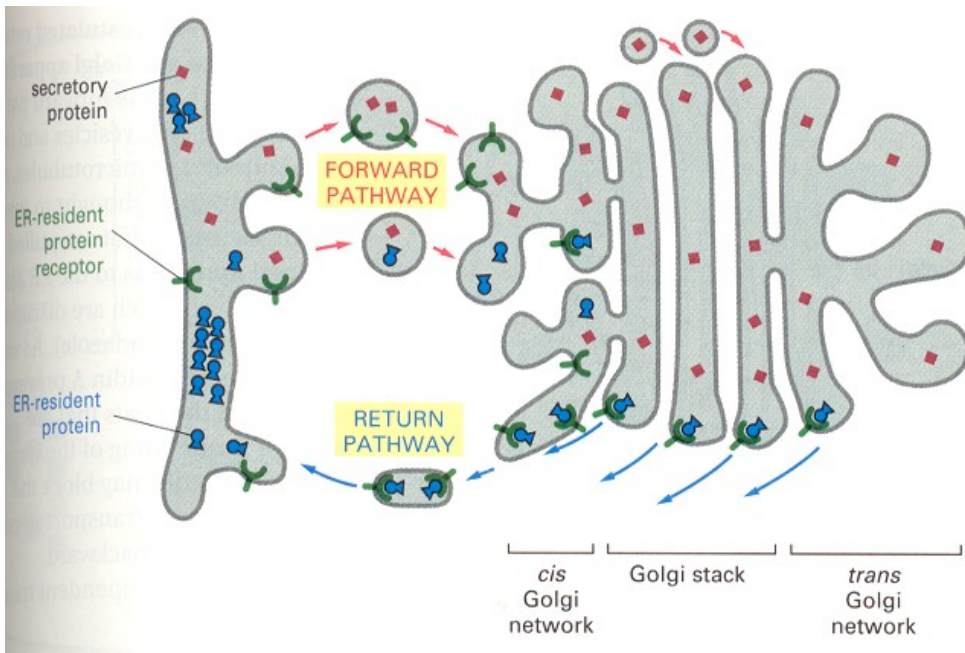

GOLGI APPARATUS: The centre of vesicular transport

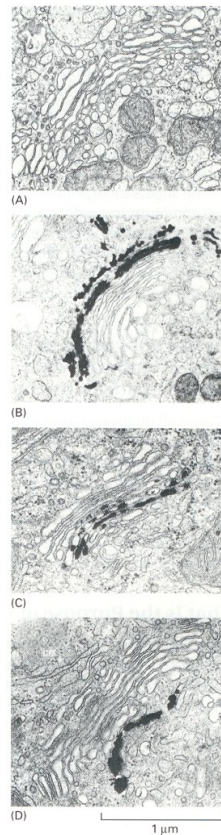
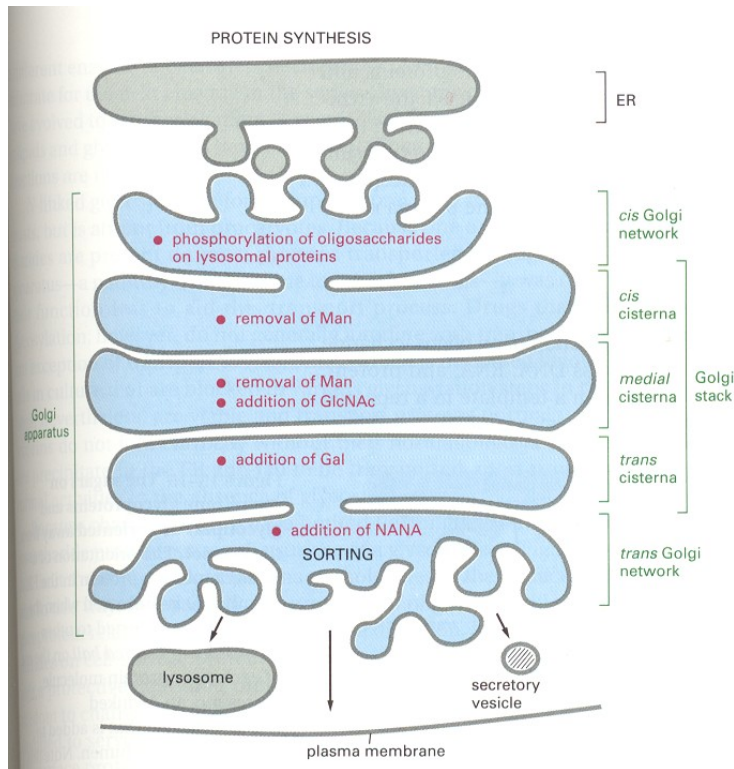

Sorting at the TGN: EXOCYTOSIS

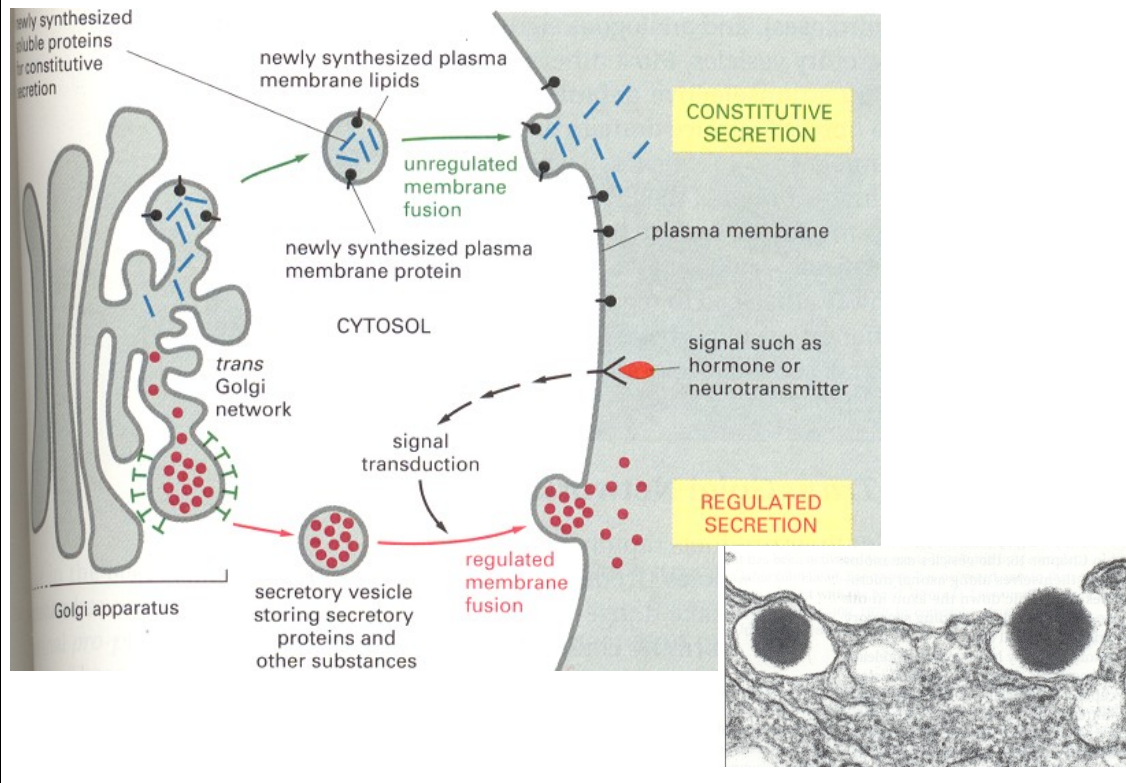

Sorting at the TGN: LYSOSOMAL ENZYMES

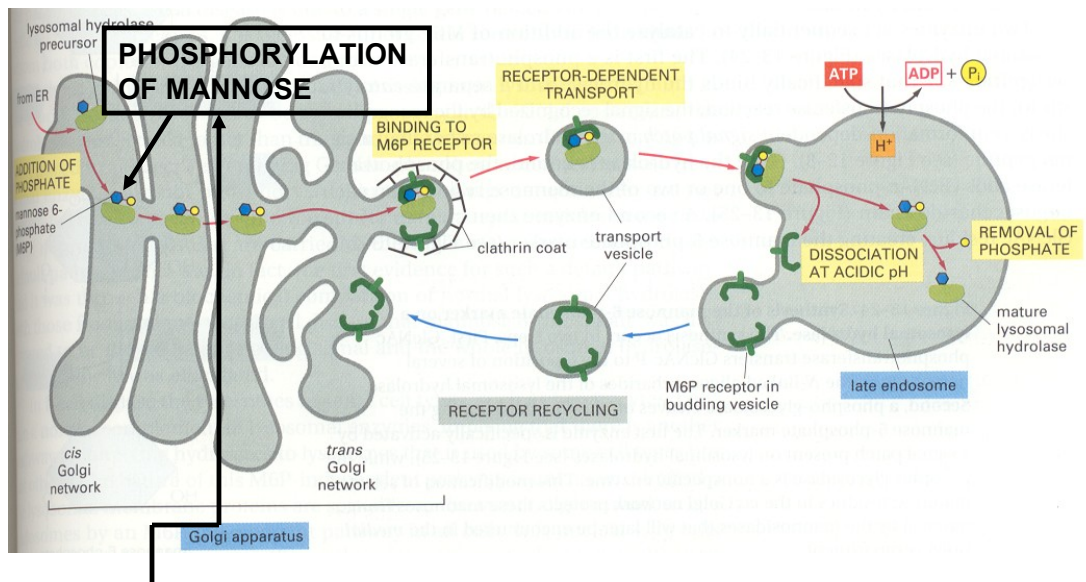

Revealed from studies on human disease (lysosomal storage disorders):
I-cell disease results from mutations in phosphotransferase

ENDOCYTOSIS

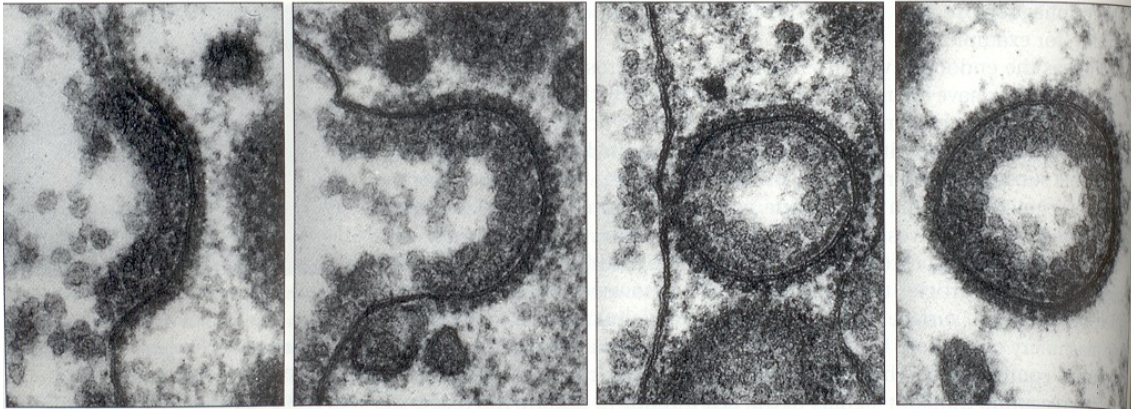

- Receptor-mediated endocytosis
- Pinocytosis
- Macropinocytosis/Phagocytosis

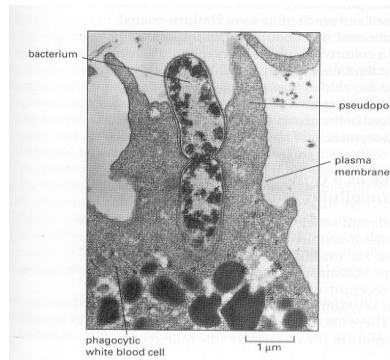

ENDOCYTOSIS: fate of endocytosed material

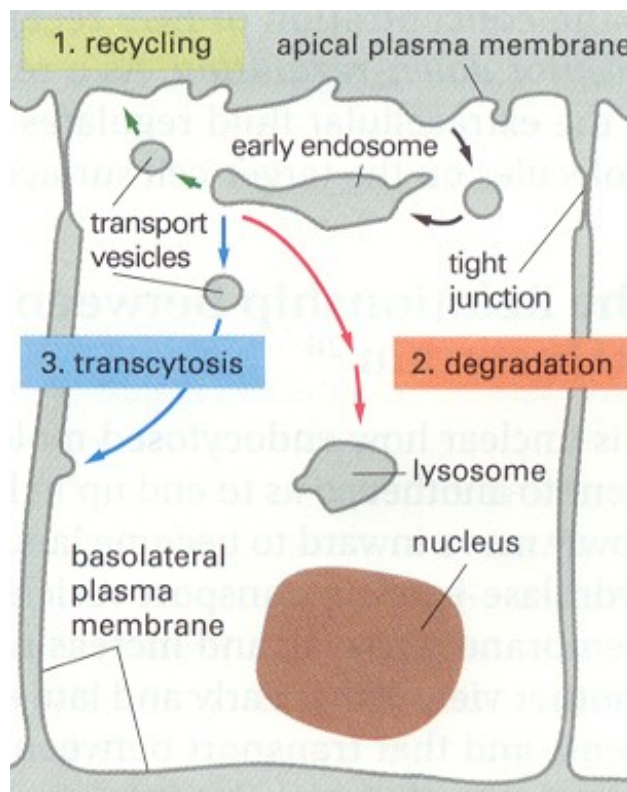

RECEPTOR-MEDIATED ENDOCYTOSIS

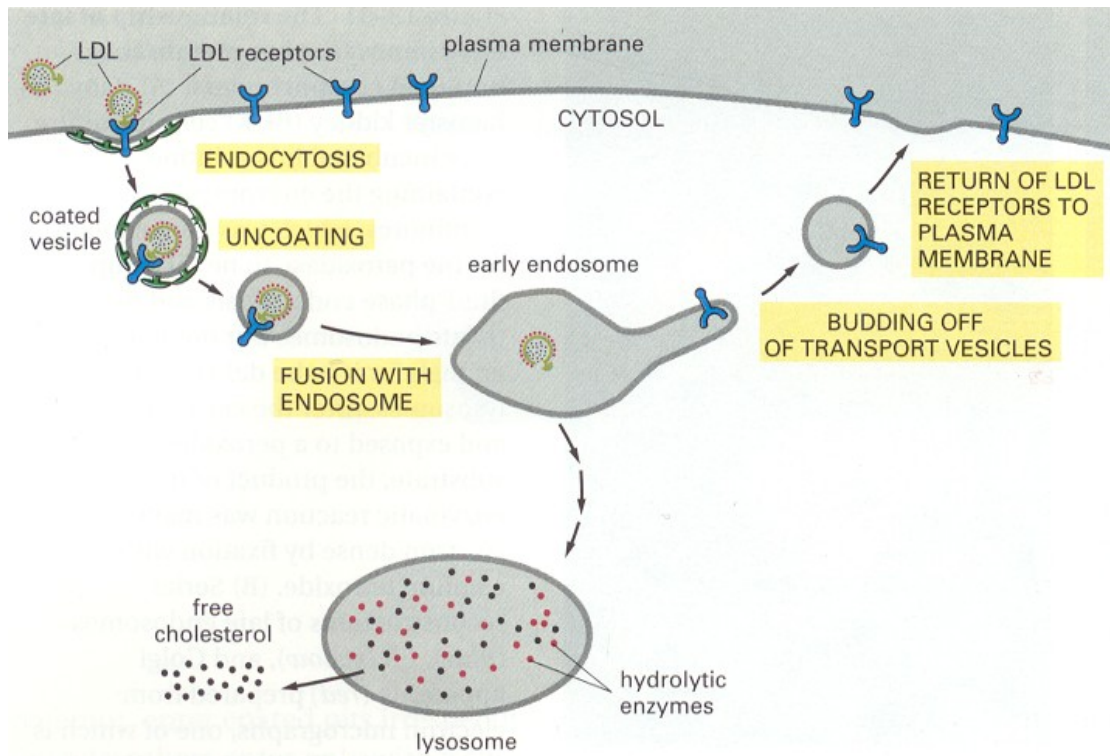

DISEASE OF ENDOCYTOSIS:

FAMILIAL HYPERCHOLESTEROLAEMIA

Mutations in LDL-receptor

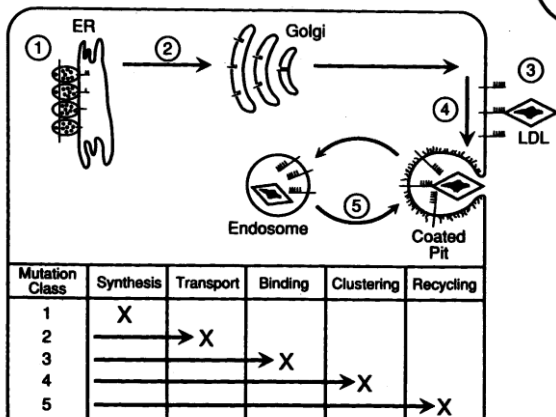
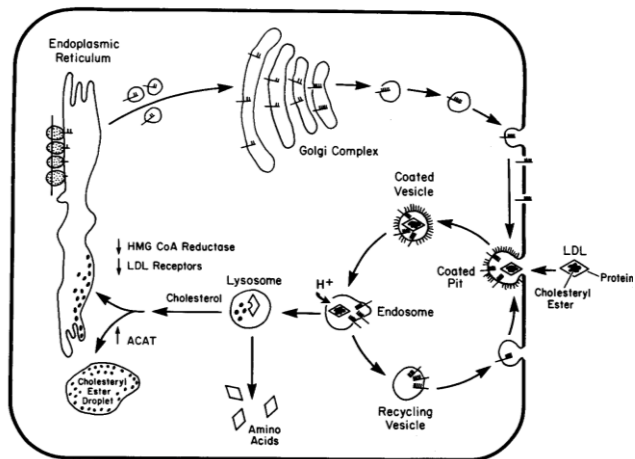

Mutation Class	Synthesis	Transport	Binding	Clustering	Recycling
1	X				
2		X			
3			X		
4				X	
5					X

STEPS IN VESICULAR TRANSPORT

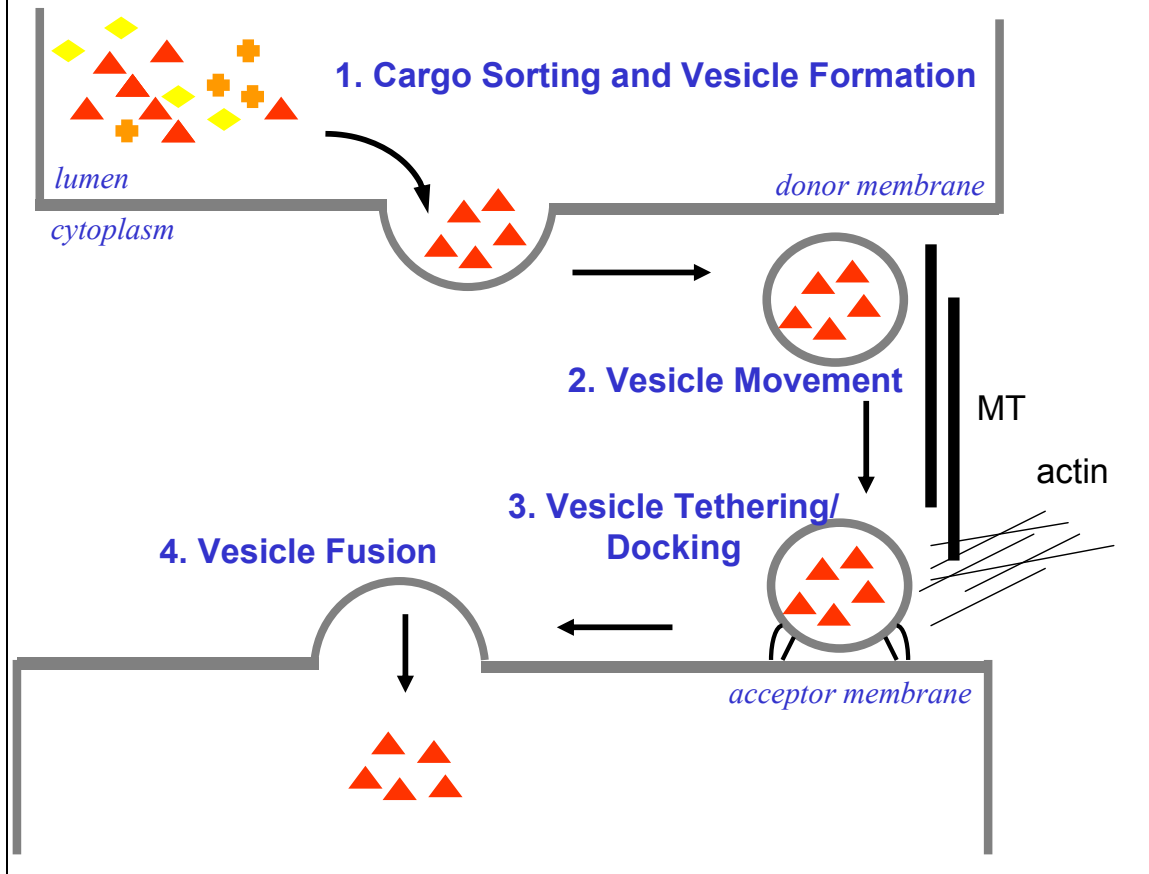

CONCLUSIONS

1. Intracellular trafficking is a critical process for any cell and each cell exhibits many trafficking steps. The main pathways are the secretory and endocytic pathways
2. The molecular mechanisms underlying trafficking are very complex. Vesicular transport is the main mechanism and involves many different proteins
3. Intracellular trafficking is involved in many diseases including:
 - Genetic (> 75 genetic diseases or syndromes)
 - Infections
 - Cancer

LEARNING OBJECTIVES FOR MEMBRANE TRAFFICKING

- Explain the terms “endocytosis” and “exocytosis”.
- Describe the pathway and cellular locations for synthesis, post-translational modification and exocytosis of a secreted protein.
- Distinguish “constitutive” and “regulated” secretion.
- Describe the process of receptor-mediated endocytosis and the roles played by endocytic vesicles, early endosomes, late endosomes, and lysosomes.
- Give a general description of the molecular mechanisms of vesicular transport within cells
- Give examples of diseases resulting from defects in the secretory and endocytic pathways.

GENETICS 4

Cancer in families and individuals

Dr Alistair Reid

Introduction to main concepts of cancer genetics

Cancer is driven by an accumulation of genetic changes that lead to altered levels of transcription or aberrant gene transcripts. Altered levels of transcription or aberrant gene transcripts causes cancer because the resulting protein changes activate signal transduction pathways that confer a selective advantage to the cell. Commonly affected pathways include those that control cell cycle, proliferation, apoptosis, and adhesion

There are 2 classes of cancer gene: Oncogenes and Tumor Suppressors. In a normal situation, oncogenes promote cell growth/division while tumour suppressors tightly regulate it. Genetic changes cause cancer by decreasing expression of a TS gene or increasing expression of an oncogene. TS genes are usually involved in regulating cell cycle, proliferation, etc. DNA repair genes are also classed as tumour suppressors because when they are knocked out DNA fidelity is compromised therefore it is much more likely that there will be further oncogenic damage. Most TS genes require inactivation of both alleles to cause malignancy.

Common ways in which genes can be altered are via point mutation, chromosome loss/gain and chromosome rearrangements.

Familial and sporadic cancer

99% of cancers are sporadic (non-inherited); only 1% have an inherited (“germline”) component. In familial cancer a mutation in a tumour suppressor gene is inherited in the germ line. Additional somatic (non-inherited) aberrations are usually required. In sporadic cancers, all genetic aberrations are somatic.

Mutations in the genes **BRCA1** and **BRCA2** confer increased susceptibility to breast (and ovarian) cancer. These genes are normally involved in DNA repair.

<http://www.cancer.gov/cancertopics/factsheet/Risk/BRCA>

Problems with repair of DNA damage can give rise to hereditary nonpolyposis colon cancer (or Lynch syndrome).

<http://www.ncbi.nlm.nih.gov/bookshelf/br.fcgi?book=gene&part=hnpcc>

There is an animation of mismatch repair here:

http://www.hhmi.org/biointeractive/cancer/mismatch_repair.html

Abnormalities of the cell cycle caused by mutations in the APC gene are also associated with colon cancer.

Cytogenetics, fusion genes and leukaemia

There can be gross changes in cytogenetic “karyotype” in cancer and the pattern of these changes seen can be used to assess prognosis or to determine the proportion of residual cells in leukaemia.

Some leukaemias have characteristic marker chromosomes:

eg. The **Philadelphia chromosome** is a marker of chronic myeloid leukaemia (CML). It is the product of a translocation between chromosomes 9 and 22. Its presence can be monitored to assess success of therapy and to detect relapse.

<http://www.nature.com/scitable/topicpage/Chromosome-Abnormalities-and-Cancer-Cytogenetics-879>

The product of the translocation in CML is a novel gene “BCR-ABL1” caused by fusion of BCR and ABL1. Monitoring can be carried out at the microscopic level by counting the number of cells in a sample that are positive for the translocation or by molecular quantification of the proportion of BCR-ABL1 mRNA transcript in a patient’s blood sample.

Another leukaemia with a consistent fusion gene is Acute promyelocytic leukaemia, associated with fusion of PML and RARA genes via a translocation between chromosomes 15 and 17.

Pharmacogenomics

Pharmacogenomics is an emerging branch of pharmacology which deals with the influence of genetic variation on drug response. In cancer treatment, pharmacogenomic tests are used to identify which patients are most likely to respond to certain cancer drugs based on the presence of particular somatic mutations.

Examples include:

KRAS test with cetuximab for colorectal cancer

EGFR test with gefitinib for nonsmall-cell lung cancer

BCR-ABL1 T315I test with dasatinib for chronic myeloid leukaemia

NUCLEIC ACIDS AND GENE EXPRESSION 6

Analysis of Nucleic acids

Prof. Tony Magee

t.magee@imperial.ac.uk

Cell-based DNA cloning

- Construction of recombinant DNA molecules *in vitro*: cutting a target DNA and a replicon with restriction endonucleases, so that the ends of the two DNA sequences are compatible. Joining the DNA fragments by using the enzyme DNA ligase.
- Transformation of the recombinant DNA molecules into host cells (bacteria, yeast)
- Selective propagation of individual cell colonies (selectable antibiotic resistance markers).
- Expansion of the cell culture and isolation of recombinant DNA

Restriction Endonucleases

- Enzymes that cleave DNA at specific recognition sites, usually 4-8bp palindromic sequences - produce “blunt” or “sticky” DNA ends.
- The longer the recognition site, the less frequently it occurs in DNA.

Separation of DNA fragments

- Electrophoresis - DNA is negatively charged due to its phosphate backbone and moves towards the anode (+ve electrode) when an electrical force is applied to it.
- When DNA is forced to travel through a porous gel matrix (agarose / polyacrylamide gel) small fragments are retarded less than large fragments and hence travel faster.
- After resolution, DNA can be isolated from the gel or transferred to a membrane to form a replica for hybridisation.

Nucleic Acid Hybridisation

- A *key method* for detecting specific nucleic acid sequences in which homologous single-stranded DNA or RNA molecules combine via homologous base-pairing to form double-stranded molecules.
- Standard assay involves a labeled nucleic acid probe (DNA, RNA or oligonucleotide) to identify homologous related molecules in a mixture of target unlabeled nucleic acids.

Hybridisation assays

- Target DNA is immobilised on a solid support - nylon or nitrocellulose membrane - which readily binds single-stranded nucleic acid (e.g. DNA) and then hybridised with a solution of labeled probe (radioactive or fluorescent).
- Examples:
 - Southern blot hybridisation (DNA target and DNA probe)
 - Northern blot hybridisation (RNA target and DNA probe)
 - Colony blot hybridisation (bacterial DNA target, DNA probe)
 - Chromosome *in situ* hybridisation (Chromosome target and DNA probe)
 - Tissue *in situ* hybridisation (RNA target and RNA probe)
 - Reverse hybridisation – Microarrays (immobilised DNA or oligonucleotide probe, target DNA solution)

Melting temperature and hybridisation stringency

- Denaturation of a probe DNA is achieved by heating until the hydrogen bonds between the bases holding the two strands together are disrupted.
- The energy needed to do this depends on strand length (longer strand = more hydrogen bonds to break), base composition (G-C pair has one more hydrogen bond than A-T) and chemical environment (monovalent cations stabilise the DNA duplex by neutralising charge on phosphate backbone; denaturants (formamide/urea) destabilise the DNA duplex).
- Melting temperature (T_m) - measure of nucleic acid duplex stability (Hybridisation is carried out at temperatures $< 25^\circ\text{C}$ below T_m).
- Hybridisation stringency (i.e. the power to distinguish between related sequences) increases with increase in temperature and decrease in salt concentration.

Cell-free DNA cloning - Polymerase Chain Reaction (PCR)

- *In vitro* method to allow selective amplification of a specific target DNA within a heterogeneous collection of DNA sequences (e.g. total genomic DNA or complex cDNA population).
- Some sequence information is needed to design 2 primers (15 - 25 nucleotides in length), one complementary to each strand of the DNA to be copied.
- Primers are specifically annealed to heat-denatured DNA.
- Thermostable DNA polymerase + dNTPs extend from the primers and generate new strands.
- Denature the DNA and repeat the cycle many times -> geometric increase.
- Applications: typing genetic markers; Detecting or introducing point mutations; cDNA cloning; genome walking; detecting gene expression; DNA sequencing.

References

- "Human Molecular Genetics" - Strachan and Read
- "Genes" - Lewin
- "Molecular Biology of the Cell" - Alberts *et al.*

GENETICS 5

Prenatal Diagnosis

Mr Ruwan Wimalasundera

Consultant Obstetrician & Fetal Medicine Specialist

Centre for Fetal Care, Queen Charlotte's & Chelsea Hospital, Imperial College London

Aims

- Indications for Prenatal Diagnosis
- Antenatal Screening for Aneuploidy (Down Syndrome)
- Prenatal Testing
 - » Amniocentesis
 - » Chorionic Villus Sampling
 - » Fetal Blood Sampling
 - » Elective late karyotyping
- Cytogenetic Techniques
- Management options

Indications for Prenatal Testing

- High Risk of Aneuploidy
 - » High risk on Down Syndrome screening
 - » Previous aneuploid fetus
 - » Maternal request eg. Age
- Known Genetic Disorder
 - » Achondroplasia
 - » Cystic Fibrosis
 - » Haemoglobinopathies
 - » X Linked disorder
 - » Parental Balanced Translocation
- Structural Anomaly detected in Fetus on Routine Ultrasound Screening

Down Syndrome

- Most common form of mental retardation (1 in 700 pregnancies), not inherited
- Often associated with birth defects
- Variable severity, not predictable
- Due to extra chromosome: Trisomy 21
 - » Standard trisomy 21 - 95%
 - » translocation - 4%
 - » mosaic - 1%
- Risk increases with woman's age

Down Screening

Maternal age

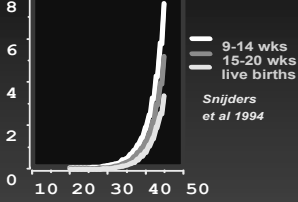

Nuchal Translucency



Serum screening

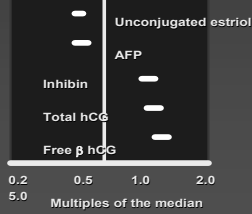

Imperial College
London



Centre for Fetal Care

After Wald et al 1998

Increased NT + Normal Karyotype

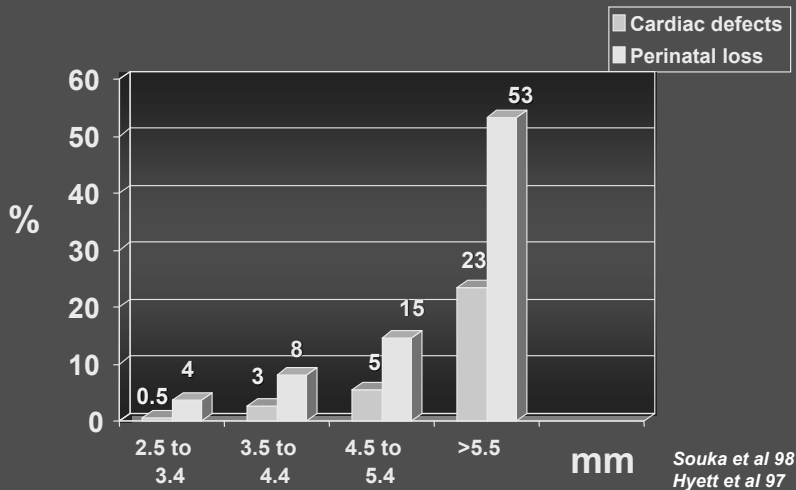

First trimester serum markers 10-14 weeks

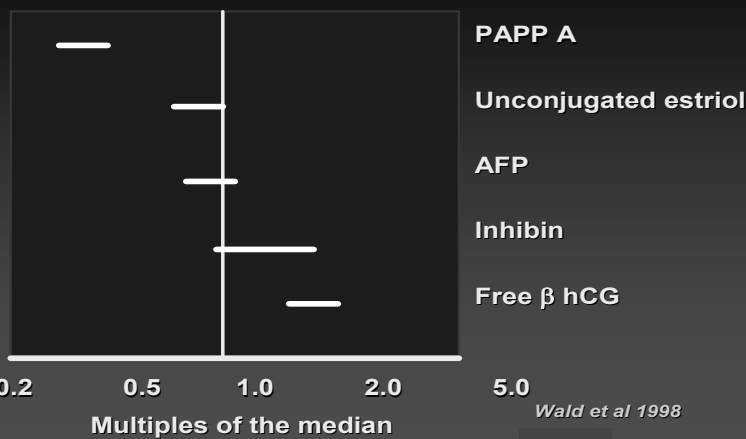

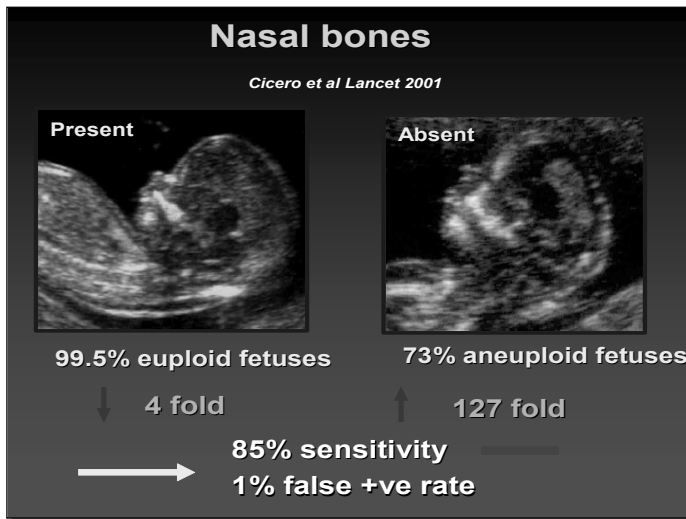

Nasal Bones

- Large population based study show poor utility of measurement
- Racial variation NB absent in 0.4% of normal Caucasian population
- NB absent in 8.8% of Afro-Caribbean population
- Large cities mixed racial groups ?%
- NB currently of limited value in T21 risk assessment

Down Screening Tests

- Triple test
14-21 weeks: AFP, unconjugated oestriol (uE3), and hCG together with maternal age.
- Nuchal Translucency Scan (NT scan)
11-136 weeks: measurement of the fold of skin on the back of the fetal neck (Nuchal Translucency) together with the maternal age.
- Quadruple test
14-21 weeks: AFP, uE3, free β -hCG (or total hCG) and inhibin-A together with maternal age.
- Combined test
10-136 weeks: NT measurement with free β -hCG, PAPP-A and maternal age.
- Integrated test
Integration of NT measurement and PAPP-A in the first trimester with serum AFP, β -hCG, uE3 and inhibin A in the second

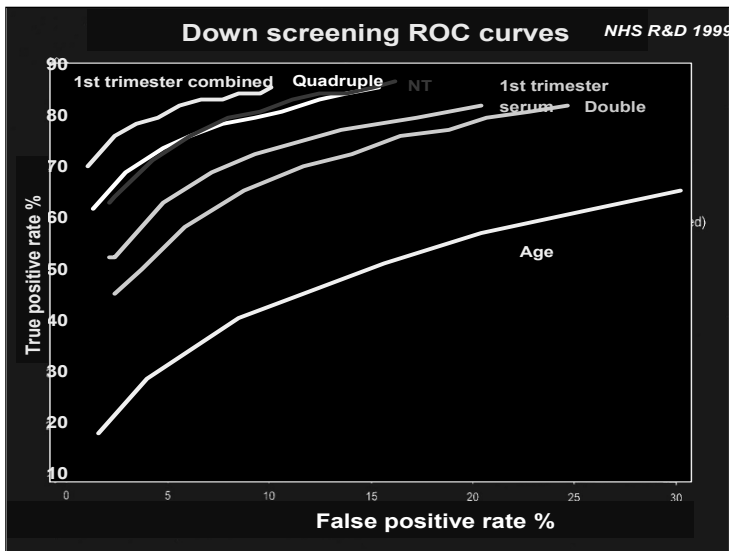

National Guidelines

- NICE- Antenatal Care Guideline
 - » April 2005 60% detection for 5% False positive
 - » April 2007 75% detection for <3% False positive
 - » At 1:250 risk cut-off at term
- April 2007
 - » Integrated Test
 - » Combined Test
 - » Serum Integrated Test

SURUSS Study				
• Multicentre study, 50,000 singleton pregnancies				
• Most effective, safe and cost effective method of screening for Down's syndrome using NT				
Test	Unaffected women referred for CVS or Amnio	No. of Down's Syndrome diagnosed	No. of unaffected fetuses lost*	No. of Down's Syndrome diagnosed per unaffected fetuses lost
Triple	4200	152	30	5.1
Quadruple	2500	152	18	8.5
Combined	2300	152	17	9
Integrated	300	152	2	76.3

Prenatal diagnosis

Chorionic villi Amniotic fluid

- ↓
- Karyotype
- DNA analysis
- Biochemical analysis

Amniocentesis

- Performed >15 weeks
- Aseptic technique - gloves, no touch
- Continuous US guidance
- Avoid placenta
- 22G needle with stylet
- Discard first 2ml
- Aspirate 15-20ml

Amniocentesis Complications

- Pregnancy loss rate:
 - 1% procedure-related miscarriage
 - Only 1 RCT (Tabor 1986), control 0.7% miscarriage, amnio 1.7%
 - Fetal Medicine Units 0.5% (1:200)
- Rh sensitisation
 - All Rh Negative women get Anti D within 72h
- 1.3% procedure-related liquor leakage
 - Usually self limiting
 - ? lung hypoplasia
 - ? postural deformities
- Infection
 - <0.1%, if suspected do repeat amnio, if GS + suggest emptying uterus
- late diagnosis / TOP

Early vs Midtrimester Amniocentesis

- CEMAT Trial (*Lancet*, Vol 351, Jan 1998)
- Early (11+0 - 12+6 weeks)
- Midtrimester (15+0 - 16+6 weeks)
- 4374 women
- Post-procedure loss rate - 2.6% vs 0.8%
- Talipes - 1.3% vs 0.1%
- Culture failure - 1.7% vs 0.2%
- Amniotic fluid leakage (<22 weeks) - 3.5% vs 1.7%

Cytogenetic Analysis

- Fetal cells concentrated in centrifuge (skin, pulmonary, urogenital, extra-embryonic membrane cells)
- Cells cultured in multiple cultures (14 days)
- Culture failure rate 0.5% (1:200)
- Maternal contamination rare
- Human error
- Culture Artifact
- Mosaicism

Mosaicism in Amnio Culture

- Finding of 2 or more cell lines with different chromosomal constitutions in amniocyte culture e.g. 46XX/47XX+21
- Most often due to culture artefact, therefore has to be present in >2 cultures to be significant (<0.2%)
- As amniotic fluid culture based on various cell types, mosaicism is most likely to represent a true mosaic in fetus
- However, if fetus structurally normal then may need further confirmatory testing such as fetal blood sampling as may be confined to fetal membranes.

CVS

- 11 weeks onwards
- Transabdominal or transcervical - USS guided
- Short term culture gives count in 48 hours
- Ideal for DNA analysis
- Tertiary referral unit
- Risk of miscarriage 0.5-2%

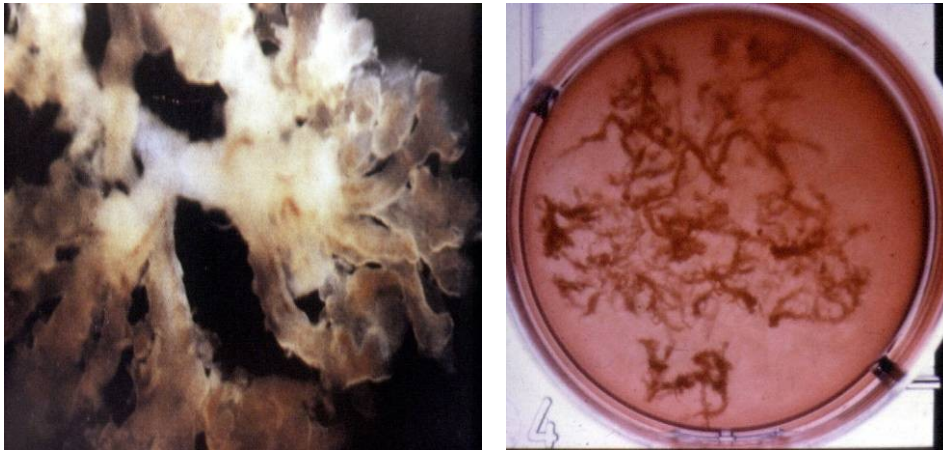

CVS Complications

- Pregnancy loss rate:
 - 1% procedure-related miscarriage
 - Background miscarriage rate higher 2%
 - Fetal Medicine Units 0.5% (1:200)
 - Clear learning curve - Should only be done in FMU
- Rh sensitisation
 - All Rh Negative women get Anti D within 72h
- Bleeding/ ROM/ Infection rare
- Fetal anomaly

Limb Defects & CVS

- CVS <10/40 5/289 limb defects (2%)
- 1:1692 background incidence
 - 1,213,000 British Columbian registry
- 1:1878 incidence after CVS (>10/40)
 - 138,000 cases in WHO CVS register
 - unrelated to gestation
 - severity and pattern similar to background

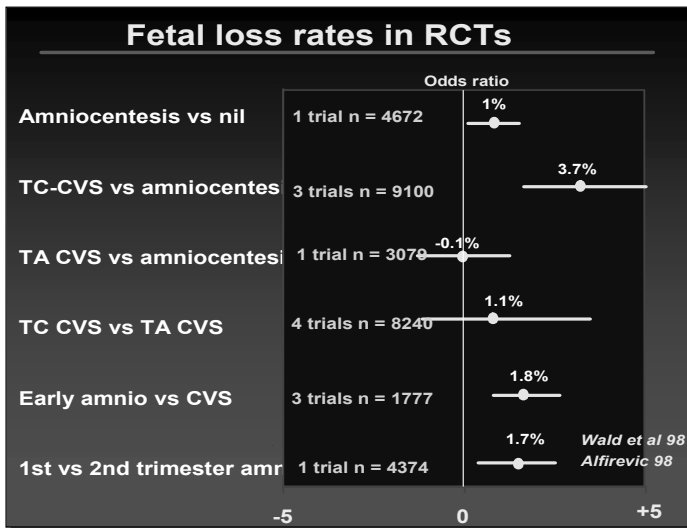

Cytogenetic Analysis

- Syncytiotrophoblast/Cytotrophoblast cells already dividing- Direct culture possible in 72h
 - Exclusively cells derived from outercell mass
- Culture cells for 14 days - Primarily fibroblasts which are derived from inner cell mass and therefore more representative of fetus
- 1:500 culture failure
- 1:200 Mosaicism - Usually confined placental mosaicism (<10% confirmed in fetus)
- 0.03% false negative

Fetal Blood Sampling

- Transabdominal USS guided
- >18 weeks
- Aseptic conditions
- CVS and Amnio are preferred for karyotype
- Primary use if for assessing fetal anaemia
- Transplacental into umbilical cord insertion into placenta
- Or transamniotic into Intrahepatic Vein

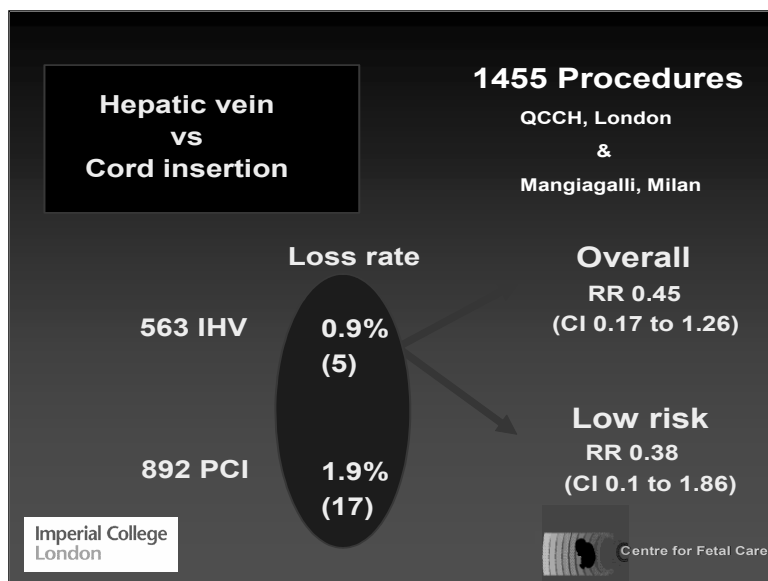

Rapid Karyotyping

- FISH
- Chromosome specific
- Fluorescence Labelled
- DNA probes

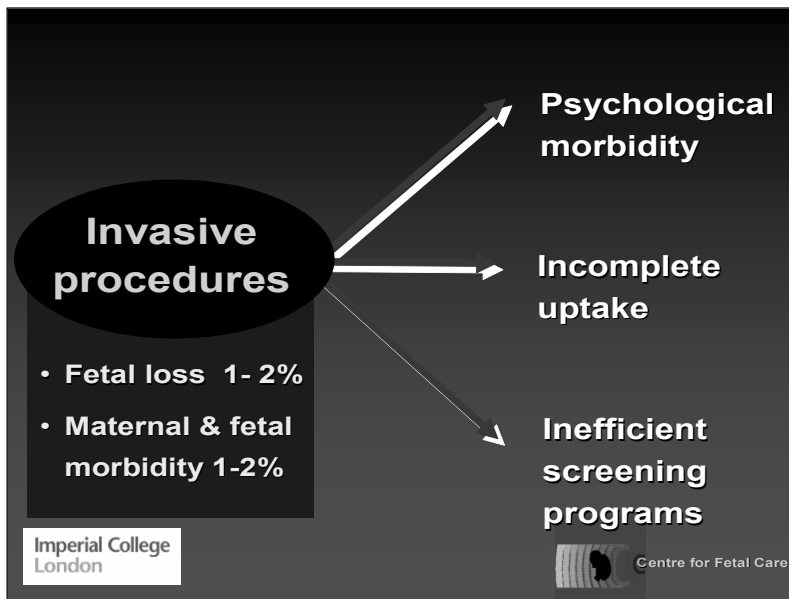
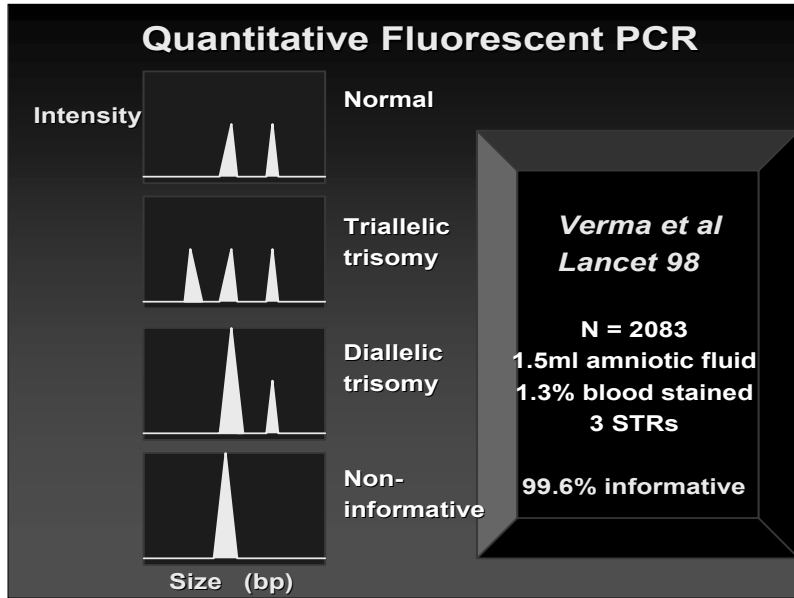

??? Genetic prenatal diagnosis ???

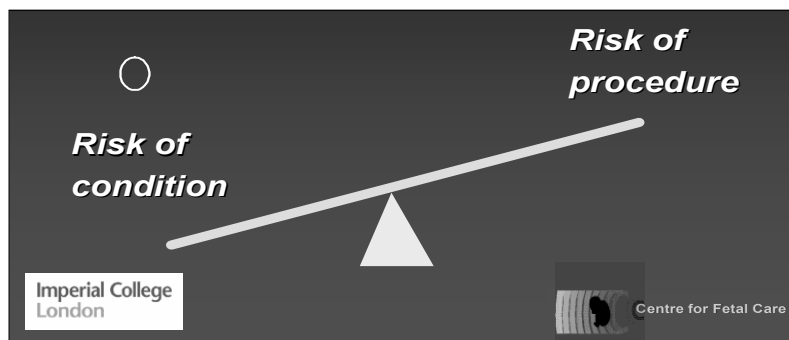

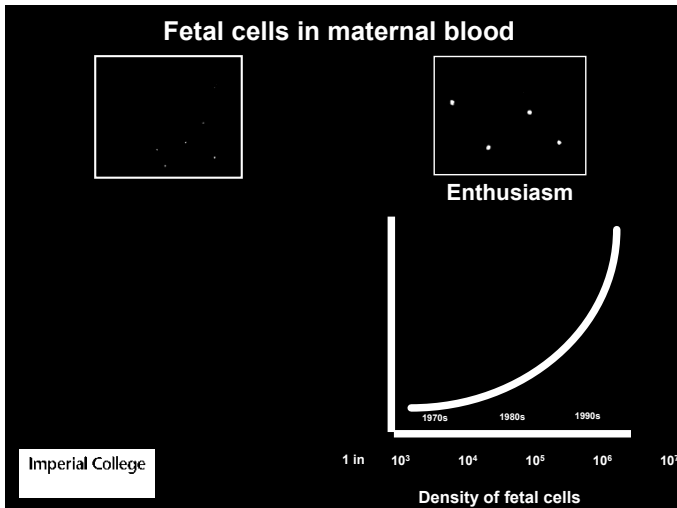
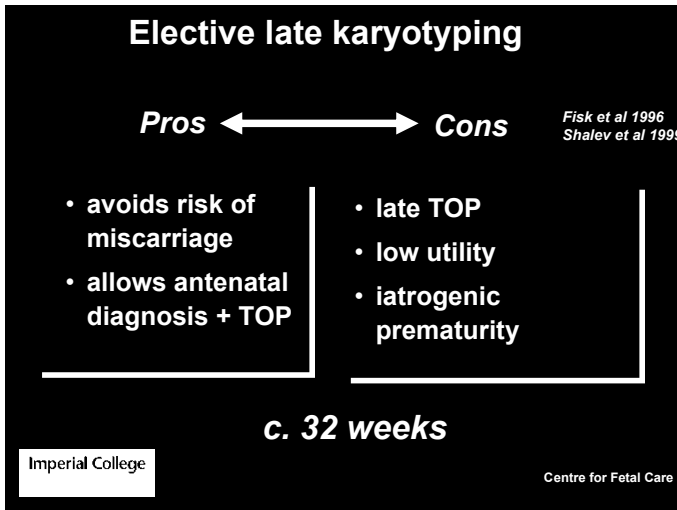

Abortion Act 1967: HFEA 1990

- A The continuance of the pregnancy would involve risk to the life of the pregnant women greater than if the pregnancy were terminated
- B The termination is necessary to prevent permanent injury to the physical or mental health of women the pregnant
- C The pregnancy has NOT exceeded its 24th week and that the continuance of the pregnancy would involve risk, greater than if the pregnancy were terminated, of injury to the physical or mental health of the pregnant women
- D The pregnancy has NOT exceeded its 24th week and that the continuance of the pregnancy would involve risk, greater than if the pregnancy were terminated, of injury to the physical or mental health of any existing children of the family of the women
- E There is substantial risk that if the child were born it would suffer from physical or mental abnormalities as to be seriously handicapped,

Terminations

- 93% of abortions carried out under clause C & D
- <1% are performed > 24 weeks
- 96% of T21 and Spina bifida performed under clause E

1967 Abortion Act: Amended by 1990 Human Fertilisation & Embryology Bill

Clause E

substantial risk that if the child were born it would suffer from such physical or mental abnormalities as to be seriously handicapped

Management Options

- Termination of Pregnancy
- Continuation of pregnancy
 - Support Parents decision
 - Offer continued USS monitoring
 - Detailed plans need to be made for
 - » Mode of Delivery
 - » Monitoring in Labour
 - » Neonatal resuscitation
 - » Postmortem
 - » Postnatal care- surgical/cardiac/neurological etc
- Genetic Counselling
 - Risk of recurrence
 - Management of future pregnancy
 - Implications to other family members

IMMUNOLOGY 1

Introduction to Immunology

Prof. Charles Bangham (c.bangham@imperial.ac.uk).

After this lecture you should be able to

- Explain the importance of immunology for human health.
- Outline the basic principles of immune responses, and the timescales in which they occur.
- Define the terms antigen, antibody, B lymphocyte, T lymphocyte, active immunity, passive immunity, primary and secondary immune responses.
- Outline the concept of clonal selection, and its role in immune responses.
- Understand the roles of *natural selection* and the *physical organization* of the immune system in its function.

Basic principles of the immune response and the timescale

Immune system recognizes non-self material that enters the body and responds to it. Innate immune system works rapidly (minutes) and has broad specificity. Adaptive immune system takes longer (days) and has exquisite specificity.

Definition of terms

Antigens are molecules which react with antibodies or T cells. However not all antigens can *induce* an immune response in the host: those that can are termed **immunogens**.

Antibody molecules can be found in the blood stream and the body fluids and bind specifically to particular molecules termed antigens. They are the *acquired* component of the *humoral* immune response.

Lymphocytes are mononuclear cells which are part of the leukocyte (white blood) cell lineage. They are subdivided into B (Bone marrow-derived) and T (Thymus-derived) lymphocytes. Lymphocytes express *antigen receptors* on their surface to enable recognition of a specific antigen

Naïve lymphocytes have never encountered the antigen to which their cell surface receptor is specific and thus have never responded to it.

Memory lymphocytes are the products of an immune response, enabling the specificity of their specific receptor to remain in the pool of lymphocytes in the body.

Innate immunity An early phase of the response of the body to possible pathogens, characterized by a variety of non-specific mechanisms (e.g. barriers, acids or enzymes in secretions) and also molecules and receptors on cells which are **Pattern Recognition Molecules** which recognize repeating patterns of molecular structure found on the surface of microorganisms. The innate immune response does not generate *memory*.

Adaptive immunity is the response of antigen-specific lymphocytes to antigen, and includes the development of immunological memory. Adaptive responses can increase in magnitude on repeated exposure to the potential pathogen and the products of these responses are specific for the potential pathogen. Also known as **Specific Immunity** or **Acquired Immunity**.

Active Immunity is the induction of an immune response by the introduction of antigen.

Passive Immunity is immunity gained without antigen induction i.e. by transfer of antibody or immune serum into a naïve recipient.

Primary Response is the response made by naïve lymphocytes when they first encounter their specific antigen.

Secondary Response is the response made by memory lymphocytes when they re-encounter the specific antigen.

T cells Originate in the thymus. They recognize antigen presented at the cell surface by MHC molecules. Surface markers found on T cells are CD3, CD4, & CD8.

B cells Originate in the bone marrow. They recognize free antigen in the body fluids. Surface markers associated with B cells are CD19, Surface Immunoglobulin Class II MHC

Clonal selection and its role in immune responses.

T and B cells produced in the primary lymphoid organs are released into the peripheral lymphoid pool. Those that meet their specific antigen proliferate and produce effector and memory cells. Those that do not meet their antigen die. The size of the peripheral lymphoid pool is regulated by homeostatic mechanisms

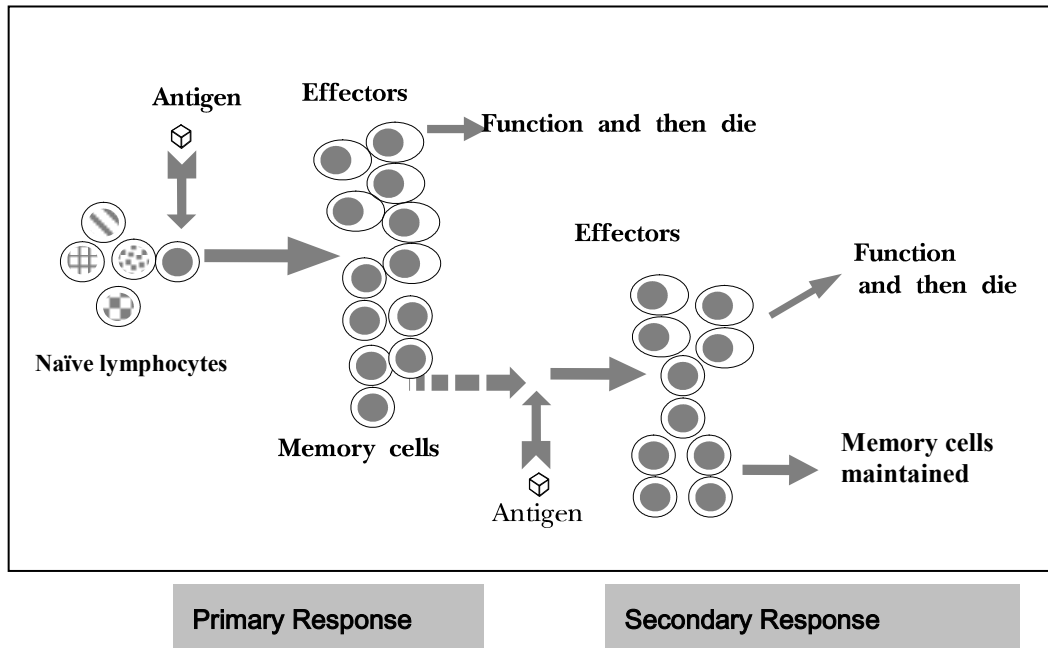

Primary and secondary responses

In the primary response, naïve lymphocytes are activated by antigen to ensure proliferation of a lymphocyte with the appropriate receptor for the antigen. This is at the centre of the immune response. After the antigen has been removed a few lymphocytes with the appropriate receptor specific for that antigen remain (the rest die). These are memory lymphocytes and memory of a specific infection can last for years.

So some years later there can be a *secondary* response which is more effective than the primary response. This greater effectiveness is due to its greater magnitude and more rapid onset than the primary response.

Physical organization of the immune system is important for its function

The tissues are patrolled by lymphocytes, antibodies and antigen-presenting cells. For example, the skin contains lymphatic vessels that drain into local lymph nodes. Gut lymphoid tissue controls responses in the intestinal tract. Antigens present in the blood are taken to the spleen.

METABOLISM 9

Integration of metabolism

Dr Gaby Da Silva

Learning Objectives

- Outline general features of metabolic activity in liver, brain, muscle, adipose tissue
- Give four examples of blood-borne hormones which act as metabolic regulators
- Know the effects of eating and fasting on metabolism
- Describe glucose interactions with lipid and amino acid synthesis & breakdown
- Know basic details of contractile metabolism in muscle
- Be able to describe some of the metabolic disturbances that arise in diabetes

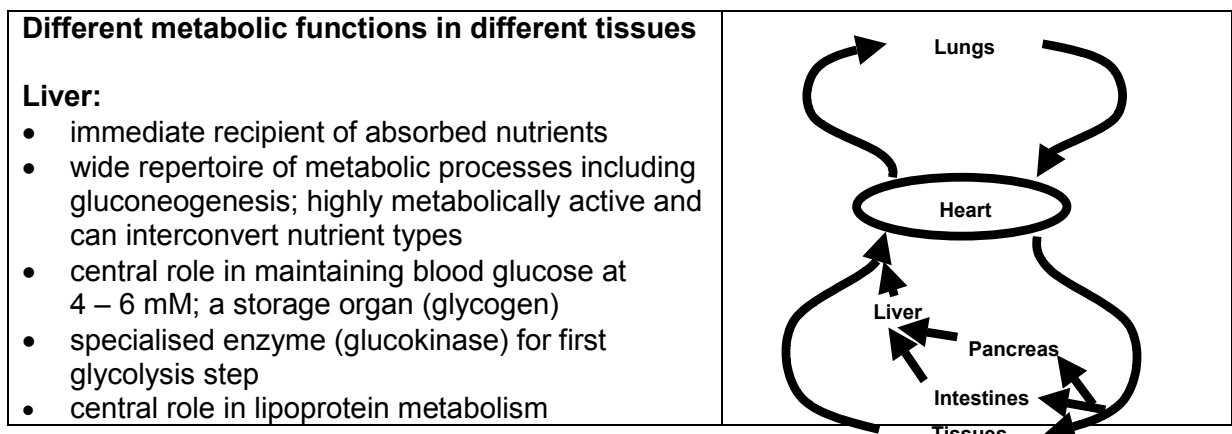
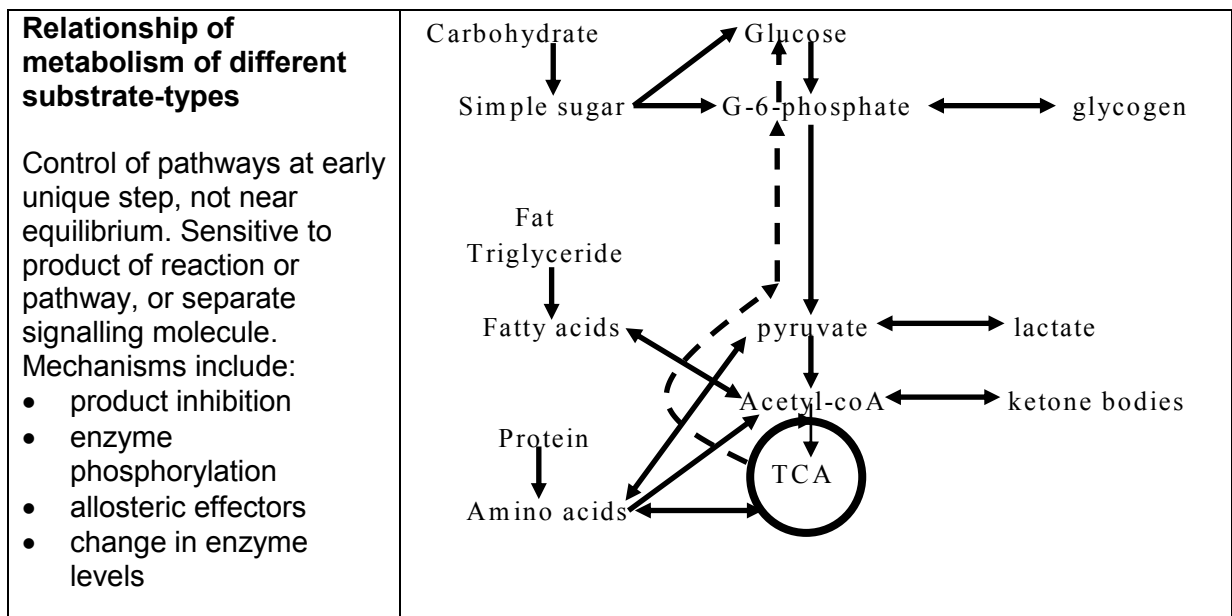

Brain and nervous tissue:

- requires continuous supply of glucose for metabolism
- cannot metabolise fatty acids
- -hydroxy-butyrate, aceto-acetate) partially \square ketone bodies (substitute for glucose)
- too little glucose (hypo-glycaemia) causes faintness and come
- too much glucose (hyper-glycaemia) can cause irreversible damage

Muscle:

- vigorous contractions can increase ATP consumption in excess of capacity to supply ATP via oxidative phosphorylation (O_2 diffusion limitation?)
- further ATP by interconversion from creatine-phosphate
- glycogen stores provide glucose for aerobic and anaerobic metabolism
- pyruvate is converted to lactate or alanine or to acetyl-CoA
- lactate/alanine transported to liver via the circulation for re-conversion to glucose (gluconeogenesis). Glucose to lactate/alanine to glucose known as Cori Cycle.

[NB Cardiac tissue is generally exclusively aerobic and can oxidise fatty acids, glucose, lactate, ketone bodies].

HORMONAL CONTROL OF BLOOD GLUCOSE IN FEEDING AND FASTING:**Upon having a meal, blood glucose initially rises and is controlled by:**

- increased secretion of insulin (and reduced glucagon) from pancreatic islets
- increased glucose uptake by liver – stored as glycogen or used in glycolysis to produce acetyl-CoA (used for fatty acid synthesis)
- increased glucose uptake and glycogen synthesis in muscle
- increased triglyceride synthesis in adipose tissue
- increase use of metabolic intermediates throughout the body due to general stimulatory effect on synthesis and growth

After a meal blood glucose starts to fall and is controlled by:

- increased glucagon secretion (and reduced insulin) from pancreatic islets
 - glucose production in liver by glycogenolysis and gluconeogenesis
 - utilisation of fatty acid breakdown as an alternative substrate for ATP production
- [NB adrenaline has similar effects on liver, but also stimulates skeletal muscle towards glycogen breakdown and glycolysis, and adipose tissue towards fat lipolysis to provide other tissues with alternative substrates to glucose]

After prolonged fasting (longer than can be covered by glycogen reserves):

- glucagon/insulin ratio increases further
- adipose tissue begins to hydrolyse triglyceride to provide fatty acids for metabolism
- TCA cycle intermediates are reduced in amount to provide substrate for gluconeogenesis
- protein breakdown provides amino acids for gluconeogenesis
- ketone bodies are produced from fatty acids and amino acids in liver to substitute, partially, the brains requirement for glucose

Diabetes is a disorder of insulin signalling

- Type I diabetics cannot make insulin
- Type II diabetics have reduced responsiveness to insulin...the effect is that the body metabolism is poised as if for starvation, regardless of dietary uptake. Complications include:
 1. Hyperglycaemia with progressive tissue damage
 2. Increase in plasma fatty acids and lipoproteins with possible cardiovascular complications
 3. Increase in ketone bodies with possible acidosis
 4. Hypoglycaemia with consequent coma if insulin dosage is imperfectly controlled

Metabolism of non-nutrient chemicals (xenobiotics) including plant metabolites, drugs, food additives, pollutants, pyrolysis products

- if water soluble can be excreted in urine or bile
- if lipophilic, metabolised to make more water soluble:
 - oxidation/hydroxylation by cytochrome P450
 - conjugation with hydrophilic molecules

[NB alcohol dehydrogenase uses ethanol to make acetyl-CoA. Hence, ethanol is an energy producing substrate, but its use is not regulated in humans]

TISSUES 2

Epithelial tissues

Dr Peter Clark (p.clark@imperial.ac.uk)

The overall aim of this lecture is to apply the information from the Tissues 1 lecture (on the sub-cellular and intercellular structures of epithelial cells) to the organisation and classification of epithelia, and to understanding the functions of various types of epithelia.

In many instances, the epithelial components of a tissue are the key functional parts, e.g. absorption, secretion, barrier-function.

Epithelial organisation

- epithelial cells make organised, stable cell-cell junctions to form continuous, cohesive layers
- epithelial layers line internal and external body surfaces and have a variety of functions, e.g. transport, absorption, secretion, protection

Epithelia are classified by:

- their cell shape, e.g. cuboidal or columnar
- their layering, e.g. single layer = simple; multi-layered = stratified

Classification of epithelia:

- simple squamous
e.g. lung alveolar, mesothelium, endothelium
- simple cuboidal
e.g. kidney collecting duct
- simple columnar
e.g. enterocytes (intestinal absorptive cells)
- stratified squamous
e.g. epidermis (skin); linings of mouth, anus, cervix and vagina
- pseudostratified
e.g. upper airway (bronchi) epithelium

Epithelial polarity

- epithelial layers have a distinct polarity, with an **apical** surface at the luminal (open) surface, and a **basal** surface in contact with the extracellular matrix
- the membrane between these two surfaces, where membranes of adjacent cells appose each other, is the **lateral** membrane
- basal and lateral membranes are usually grouped as one membrane domain: the **basolateral** membrane

Epithelial polarity

- secretion, transport, absorption etc. must usually be unidirectional
- polarity is required to give directionality to epithelial function
- membrane polarity is key to epithelial polarity
- junctions separate membrane into two biochemically and functionally distinct domains: the apical and basolateral domains

The intestinal epithelium is simple columnar, with both absorptive and secretory cells

Absorptive epithelium:

carriers transporting nutrients etc. are found on the brush-border membranes, e.g. absorptive intestinal cells (enterocytes); kidney proximal tubule cells.

Secretory cells (goblet cells secreting mucous) are interspersed among the absorptive cells.

Protective epithelia are usually stratified-squamous (e.g. epidermis)

Multiple layers of cells provide good protection of underlying tissues.

Epithelial Proliferation

Many epithelia are constantly “turning over”, i.e. cells that are lost by cell death or by mechanical removal (e.g. abrasion) are replaced by the proliferation of stem cells within the epithelium.

Two examples of this are:

1. Cells of the basal layer of stratified squamous epithelia divide to replace cells lost from the surface.
2. Cells in intestinal crypts replace cells lost from the tips of intestinal villi.

Hyperproliferation of basal cells of stratified squamous epithelial can be caused by papilloma virus, resulting in a surface growth, e.g. wart. Repeated or constant pressure to an area of the skin can cause local hyperproliferation leading to “hard skin” and “corns”.

Inhibition of proliferation of intestinal crypt cells, e.g. in cancer chemotherapy, results in loss of the finger-like intestinal villi and flattening of the intestinal mucosa. This is responsible for many of the gastro-intestinal disturbances that are side-effects of chemotherapy.